

[圧力]の種類を以下に示す。0, 500, 1000
 Selection of pressure sensor types, to be entered in "[圧力(pressure)]"
 as the model, is shown as follows : 0, 500, 1000

[電源]の種類を以下に示す。BT, AC, DC
 Selection of power supply types, to be entered in "[電源(power supply)]"
 as the model, is shown as follows : BT, AC, DC

※メーター及び配管フランジに接触し破損の恐れがあるため、表示部フタはゆっくり開けてください。
 Due to the risk of damage from contact with the meter or pipe flanges,
 please open the cover slowly.

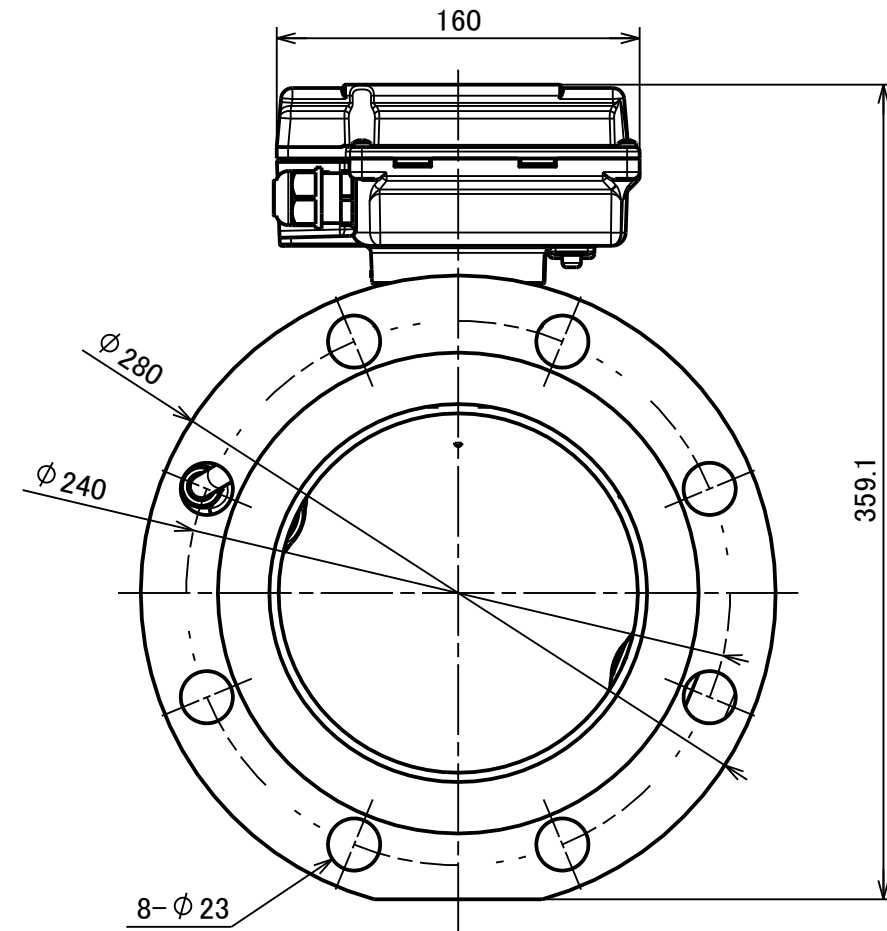
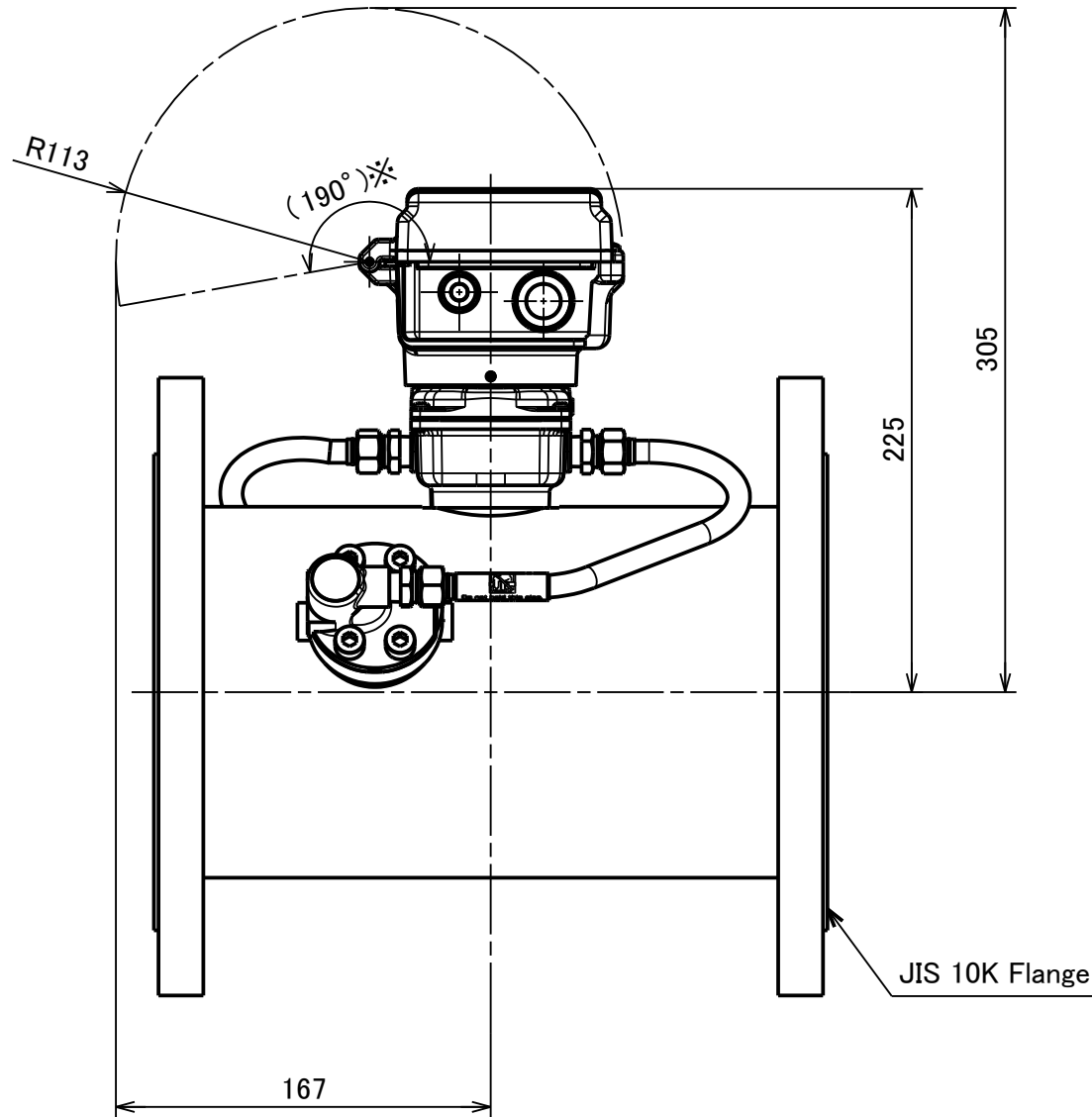
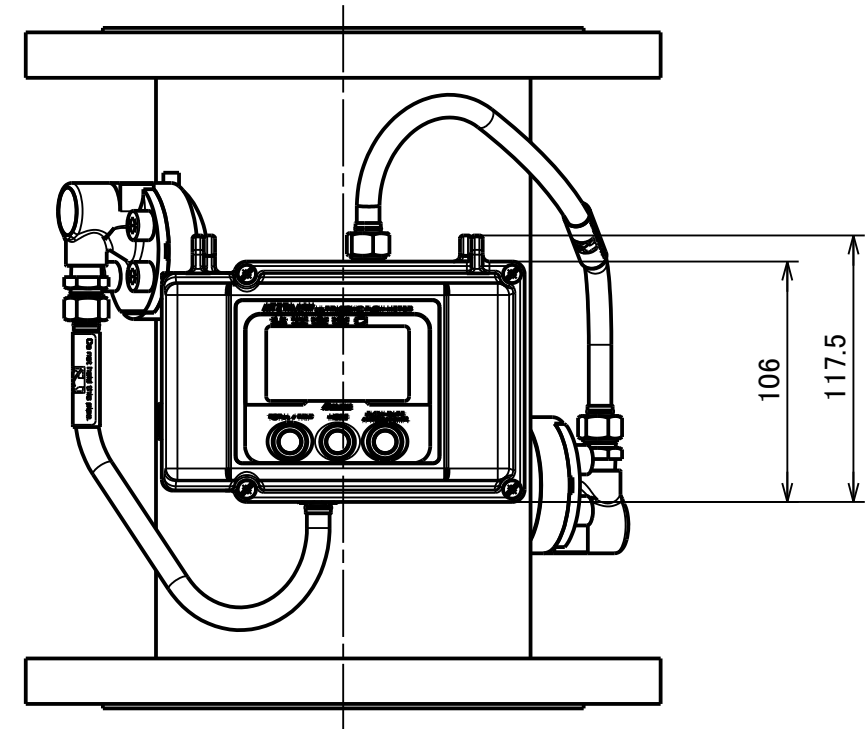

UW150-[圧力][電源]-U
 型 式
 MODEL

尺 度 SCALE	年 月 日 DATE 2024/03/12	名 称 NAME Ultrasonic Flow Meter for Management of Fuel Gas	図 番 DRAWING NUMBER UW150-[圧力][電源]-U
--------------	--------------------------	--	--