

Ultrasonic Flow Meter for Management of Fuel Gas Model ATZTA UX25s/32 (25A, 32A) Operation Manual



Aichi tokei

Introduction

Thank you very much for purchasing the High performance Ultrasonic Flow Meter UX/UZ Series for Fuel Gas this time. Please be sure to read this Operation Manual to use this product correctly and safely and to prevent accident.

Please arrange for operators who actually use this product to know the context of this Operation Manual surely. This Operation Manual is necessary for performing maintenance, too. Please keep the Manual in a safe place until this product is disposed of.

Confirmation of package contents

Upon delivery of the product, confirm that the following items are contained in the package before using the product:



Name	Quantity	Remarks
Ultrasonic flow meter	1	
Operation manual (this document)	1	
Hexagonal wrench	1	
Sunshade cover	1	Option



If there is any incorrect item , shortage, or any defect in the external appearance, please contact your nearest branch or sales office.

Safety concerns

To ensure the safe use of this product and to prevent an accident or an unexpected situation, instructions to which attention must be paid are indicated with the following symbols.

Structure of warning indications

 Danger	Incorrect handling by ignoring to follow instructions of this symbol may lead to imminent danger of death or serious injury.
 Warning	Incorrect handling by ignoring to follow instructions of this symbol may lead to possibility of death or serious injury.
 Caution	Incorrect handling by ignoring to follow instructions of this symbol may lead to injury and/or properties loss (product damage, etc.).

	This symbol indicates acts requiring “caution” and that improper operation may result in an accident.
	This symbol indicates “prohibited” acts.
	This symbol indicates “mandatory” acts that you should observe strictly.

Precautions for use

 Danger	<ul style="list-style-type: none">⊘ 1. Do not use for applications that require safety, such as nuclear, railroad, aircraft, vehicle, playground equipment, etc.⊘ 2. Do not modify the product.⊘ 3. Do not use the product for foods, drinks, medical purposes, etc., because it is not designed for sanitary specifications.⊘ 4. Do not use the product in the atmosphere of an inflammable gas, etc., because it is not designed for explosion-proof specifications. The meters do not conform to ATEX (explosion-proof) directive (2014/34/EU).
--	---

Working environment and applicable fluid

 Caution	<ul style="list-style-type: none">⊘ 1. Do not use gases any other than city gas (13A), propane gas, butane, nitrogen gas, and argon.ⓘ 2. Observe the temperature and humidity ranges (-10 to +60°C and 90%RH or lower) and operating pressure range ([UX] 0 to 100 kPa (gauge pressure) in use.⊘ 3. Avoid usage in an atmosphere containing a corrosive gas (chlorine, hydrogen sulfide, etc.) and/or for an application to a fluid containing a corrosive gas.⊘ 4. This product is not of a perfect waterproof structure (IP64). Do not install it at a place that may be submerged in water.ⓘ 5. Install the flow meter as far away from an electric noise source as possible. If you install the flow meter near an electric noise source, it is recommended to use a shield wire as a cable which is connected to the flow meter. In this case, ground the shield wire to FG of any device other than the flow meter.6. The installation of a sunshade is recommended if the flow meter is exposed to direct sunlight.7. If you use the flow meter for propane or butane, use it under conditions where there is no oil mist state due to re-liquefaction, etc. If oil mist is affixed inside the flow meter, it may cause a failure in flow-rate measurement, resulting in incorrect measurement.8. The accuracy stipulated in the specifications may not be satisfied under the environment where there is pulsation. It is recommended to install the flow meter at a location where there is little pulsation.9. If sharp pressure change occurs, such as when gas in the pipe is discharged, correct measurement may not be performed. For this reason, after the fluid is changed to the subject fluid for measurement, reboot the power or reconnect the battery while no fluid flows (0 m³/h).10. For the type without pressure sensor, set the gas pressure value (gauge pressure) [F5]. (If the setting value and actual pressure do not match, the flow-rate measurement accuracy may not be satisfied.)11. When you use the flow-rate conversion function at high elevations, set the atmospheric pressure of the working environment [F19]. (If this setting is not made, a range caused by conversion may become larger.)
---	--

Working environment and applicable fluid

 Caution	12. When installing it at the upstream or downstream of the governor, install it 10D or more away from the governor. (An incorrect flow-rate measurement may occur due to an effect of the governor.)
	13. After the subject fluid for measurement is set, turn on the power while no fluid flows (0 m ³ /h).
	14. Since the variance of the instantaneous flow-rate may become larger due to an effect of the governor, it is recommended to set 16 times to the instantaneous flow-rate moving average number of times.















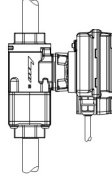
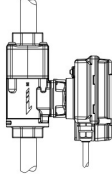
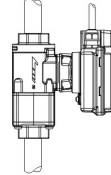



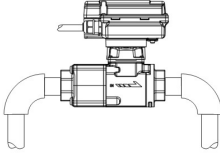
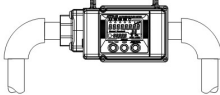
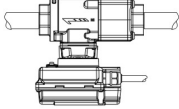



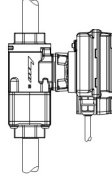
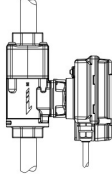
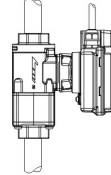

Cautions for operations

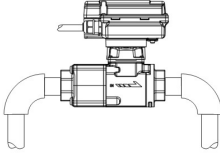
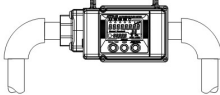
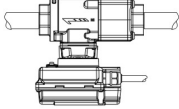
 Caution	This product is not a specified measuring instrument defined in Japanese measurement law.
---	---

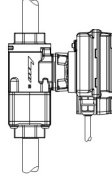
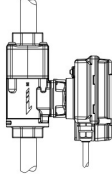
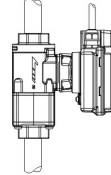

Storage

 Caution	<ul style="list-style-type: none">⊘ 1. Store the flow meter at a place away from fire and not exposed to direct sunlight.⊘ 2. Do not place any combustible material, inflammable substance and heating body in the periphery of the flow meter.ⓘ 3. Store this product at a place whose ambient temperature is -20 to +70°C and where no dew condensation occurs.
---	---

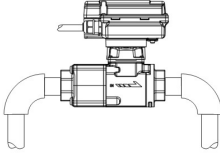
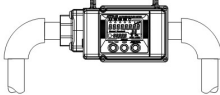
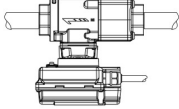
Piping

 Warning	<ul style="list-style-type: none"> ⊘ 1. Do not climb on this product using it as a foothold. ⊘ 2. Do not carry and/or install this product as holding its display. 												
 Caution	<ol style="list-style-type: none"> 1. When you install the flow meter, be sure to turn off its power. After the flow meter is installed, set the subject fluid for measurement and turn on the power while no fluid flows (0 m³/h). 2. In the case of new piping, install the product after sufficient cleaning of the pipe(s). 3. It is recommended to use rising piping to install the flow meter if the air contains oil mist, dust, or other materials. If oil mist and/or dust accumulates inside this product, it may cause performance failure and/or defects. Installation in which the display part faces downward and the cable introduction part faces upward cannot be performed. <div style="text-align: center; margin: 10px 0;"> <table style="width: 100%; border: none;"> <tr> <td style="text-align: center;">  Recommended </td> <td style="text-align: center;">  Not recommended </td> <td style="text-align: center;">  Incorrect </td> </tr> <tr> <td style="text-align: center;">  </td> <td style="text-align: center;">  </td> <td style="text-align: center;">  </td> </tr> <tr> <td style="text-align: center;">  Recommended </td> <td style="text-align: center;">  Not recommended </td> <td style="text-align: center;">  Incorrect </td> </tr> <tr> <td style="text-align: center;">  </td> <td style="text-align: center;">  </td> <td style="text-align: center;">  </td> </tr> </table> </div> <ol style="list-style-type: none"> 4. Do not install the flow meter in sections where it will be subjected to significant compression forces, tensile loads, and other loads after it is installed. 5. Install the product along with the flow direction indicated on the product. 6. Do not drop the product, hit it, or apply excessive impact. 7. When turning the display unit, do not apply force to any direction other than the rotational direction. In case any force is applied to direction to pull up or push down the display, the display may come off which can lead to breaking of the internal wires, etc., or may not rotate smoothly. 8. When making piping connections, make sure that foreign material such as weld chips, debris, and sealant do not make their way into the pipe. 9. When tightening the pipe, do not apply excessive torque. 10. Installation of a strainer (60 meshes) at the upstream side of the meter is recommended. (In case of dust adherence on the internal mechanism portion, the flow meter may not be able to satisfy the measurement accuracy.) 	 Recommended	 Not recommended	 Incorrect				 Recommended	 Not recommended	 Incorrect			
 Recommended	 Not recommended	 Incorrect											
													
 Recommended	 Not recommended	 Incorrect											
													

Wiring

 Danger	<ul style="list-style-type: none"> ❗ 1. When performing wiring work, follow the instructions in this Operation Manual. ❗ 2. Use the product within the rating. ⊘ 3. Do not use the product on a voltage exceeding permissible load.
 Caution	<ul style="list-style-type: none"> 1. Do not place the product's external connection cable together with or near to power supply line(s) or power line(s), etc. of other devices. 2. Electrical isolation of a remote counter (a receiver) from others is recommended. 3. Do not pull the cable connected to the terminal mount forcibly. 4. Ensure that the tip of the cable connected to the terminal mount is not soaked in water during wiring work, etc. ❗ 5. When connecting the power supply wire to the terminal mount, be careful not to short-circuit it. Use an external power supply having a short-circuit protecting function. ❗ 6. Be sure to perform the wiring work in a state that power supply from the external power supply is interrupted. ⊘ 7. Do not perform operation and the wiring work with wet hands. ❗ 8. For external power supply type (24 VDC, 100 VAC), install a power switch to the power supply system for this product to prevent electrical shock when connecting and disconnecting cables to and from a power supply terminal. ❗ 9. For external power supply type (24VDC), when you ground power supply, ground the 0V terminal. Since the casing is conducted with GND (signal ground), if the 24V(+) terminal is grounded, it is to be short-circuited with the FG of your device. For this reason, be sure not to ground the 24V(+) terminal. ⊘ 10. For external power supply type (100VAC), do not connect the ground wire of the cable to the flow meter. ⊘ 11. For external power supply type (24 VDC, 100 VAC), do not ground the positive terminal of the analog output line. Since the casing is conducted with SG (0 V), if the positive terminal of the analog output line is grounded, a current loop which bypasses analog output is formed, and analog output is not transmitted correctly. 12. Connect the internal battery when you use the flow meter. [Internal Battery Type] *Battery life: 5 years after the power is turned ON. (Standard conditions: Temperature 20°C, humidity 65%RH) 13. When you replace the internal battery, follow the instructions given in this operation manual. Perform the switch operation (press SW1 and SW2 at the same time for 3 sec or more while the entire LDC is turned ON, and the symbol and unit flicker every 2 sec) and confirm that the screen indicating completion of battery replacement is displayed ("1" and the symbol and unit flicker every 2 sec).

Disassembling and inspection

 Caution	<ul style="list-style-type: none">1. Do not disassemble this product.2. When fluid flow is normal, the pilot lamp will blink. If it does not blink, please contact the company you purchased the product from or our branch or sales office.
---	---

Disposal

 Warning	<ul style="list-style-type: none">1. This product contains a lithium battery, and therefore be sure not to dispose it in the general disposal route. [Internal Battery Type]2. Be sure not to put this product into fire. It may cause fire and/or explosion.3. Since the flow meter is made by putting metals and resin parts together, it must be discarded as industrial waste.
---	--

Ultrasonic Flow Meter for Management of Fuel Gas

AZTZA UX Series Operation Manual

● Table of contents

Introduction	1
Confirmation of package contents.....	1
Safety concerns.....	2
1. Overview	1
1-1. Outline of product	1
1-2. Model configuration	1
1-3. Name of each part.....	2
1-4. Dimension drawing	3
2. Before using the product.....	4
2-1. Connection of battery	4
2-2. Wiring connection	6
2-3. Installation.....	14
3. Start up procedure	18
3-1. When the power is turned on	18
3-1-1. Abnormal in ultrasonic measurement.....	18
3-1-2. Abnormal temperature value	19
3-1-3. Aberrant pressure value	19
3-2. When operation starts	19
4. Operation Procedure	20
4-1. Display of measurement values (measurement mode)	22
4-1-1. Conversion display	22
4-1-2. Display of accumulated flow volume	22
4-1-3. Display of instantaneous flow-rate, temperature, pressure.....	23
4-2. Measurement of very small flow-rate (Test mode time selection).....	24
4-3. Setting of parameters (Settings mode)	24
5. Alarm Display.....	25
5-1. Abnormal ultrasonic measurement.....	25
5-2. Battery replacement alarm [Internal Battery Type].....	26
5-3. Abnormal temperature value	27
5-4. Abnormal pressure value (Type with pressure sensor).....	27
5-5. Abnormal compensation (Type without pressure sensor).....	27

5-6. External memory abnormality.....	28
5-7. In the case of power outage (DC type, AC type).....	28
6. Troubleshooting	29
7. Specifications.....	30
7-1. List	30
7-2. Glossary of terms used in specifications.....	32
8. Setting of parameters	33
8-1. Details of setting items	38
Warranty and after-sale service	47
1) Warranty period	47
2) Scope of warranty.....	47
3) Requesting for service.....	47
4) Points to note for long-term use	47

1. Overview

1-1.Outline of product

This product is an ultrasonic flow meter mainly for fuel gas and capable of measuring the flow-rate at atmospheric pressure up to 100 kPa.

The flow meter is installed to pipes by screwing its taper pipe threads to the pipes or by being tightened between pipe flanges.

- Screw connection type (Taper pipe threads) applied model: UX

In addition, the flow meter is certified according to the following standards (except 100VAC type).

EN61326-1 : 2013 table2(EMS)

EN55011:2009+A1:2010 Group 1 ClassA(EMI)

1-2.Model configuration

Basic model	Nominal diameter	Compensation category	Power supply	Flow direction	Gas type	Description
UX	25s	0	BT	L	13A	Screw connection
	32	100	DC	R	PRO	25A
			AC	U	BTN	32A
				D	N2	Type with pressure sensor
					AR	Type without pressure sensor
						BT: Dedicated lithium battery
						DC: 24 VDC ± 10%
						AC: 100 VAC ± 10%
						Left -> Right
						Right -> Left
						Down -> Up
						Up -> Down

1-3. Name of each part

1) Flow meter main unit

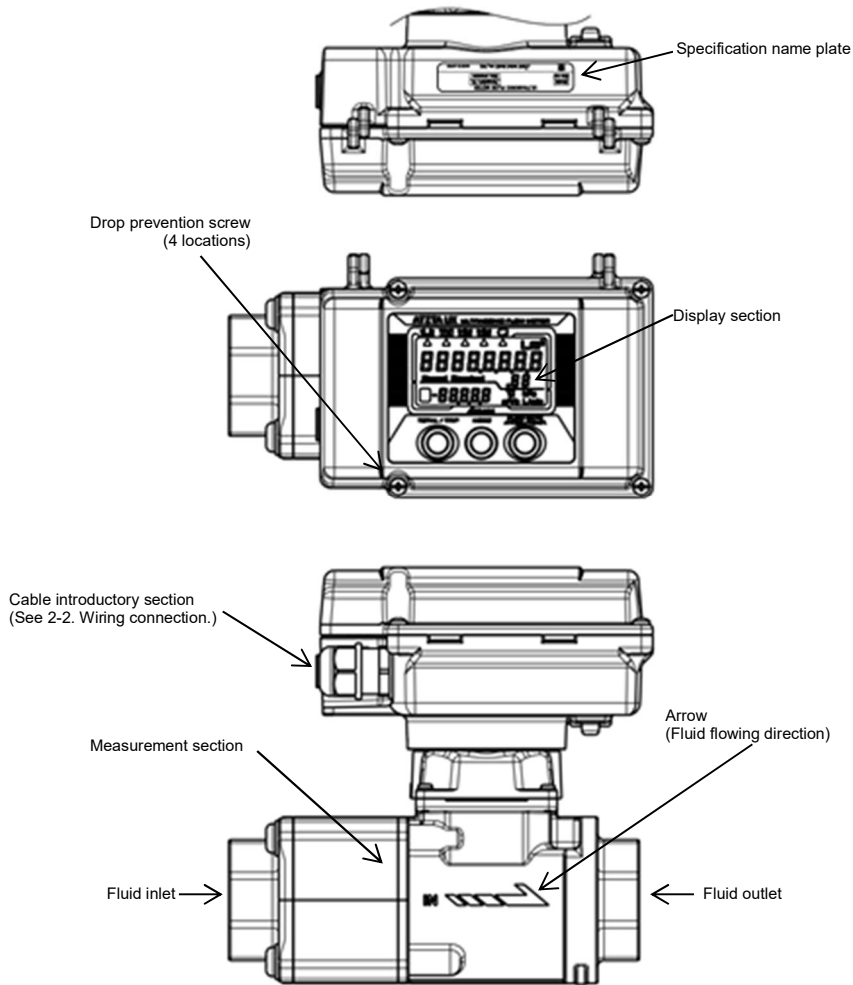

2) Display

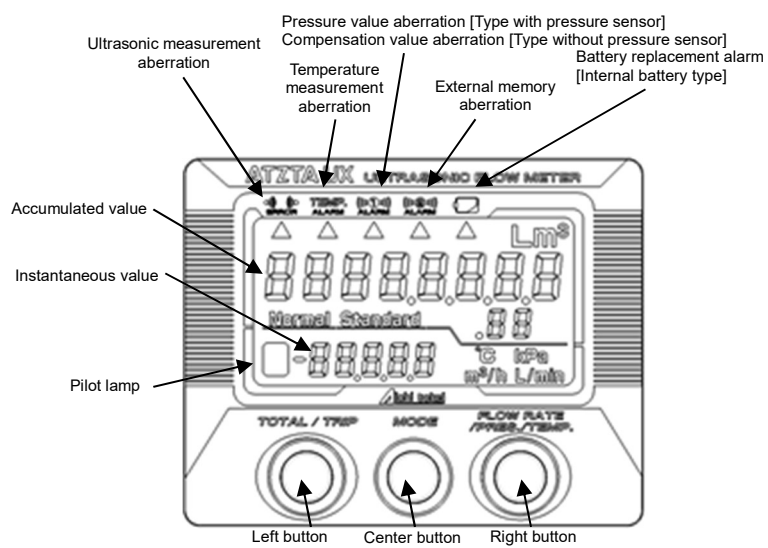

*For button operation, refer to "4Operation Procedure".

1-4.Dimension drawing

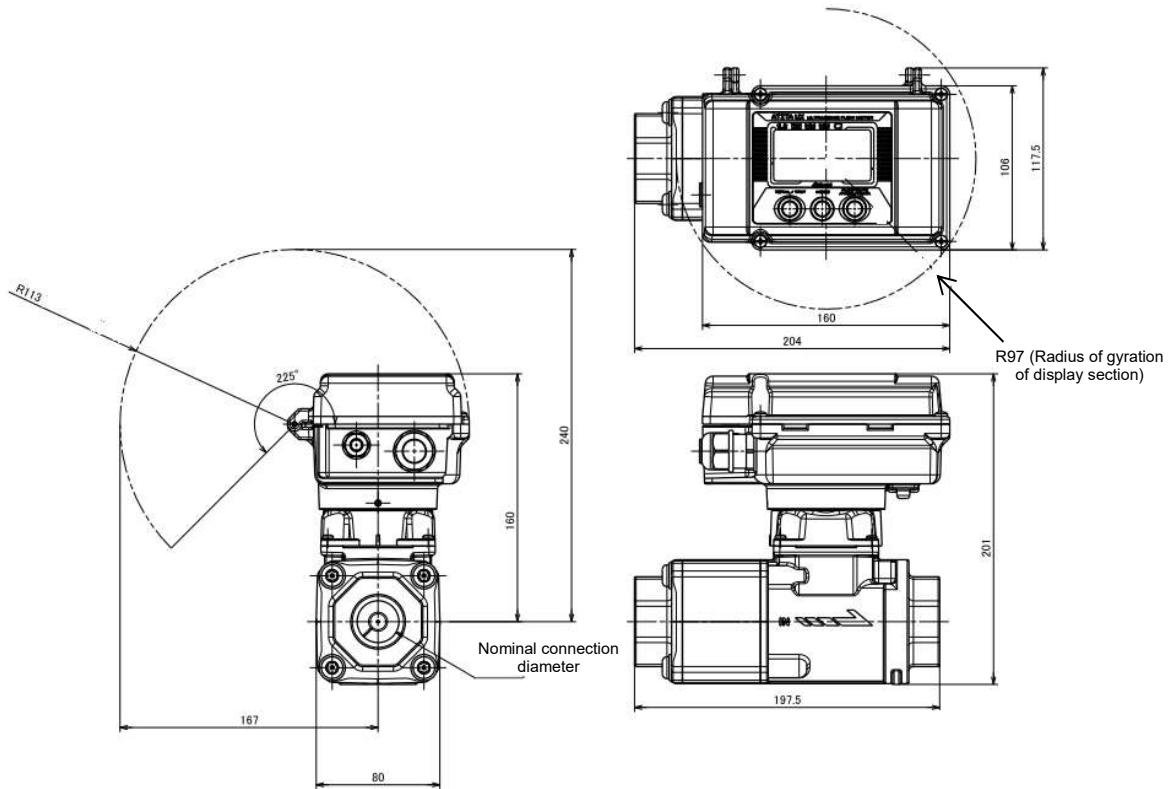

Model	Connection diameter
UX25s	Rc1
UX32	Rc1 · 1/4

2. Before using the product

With this flow meter, items concerning measurement, output, and communication can be set.

At the time of purchase, the standard factory delivery settings have been made, and the user can use the flow meter as it is. Change the settings according to the usage, if needed. The settings can be changed by button operation and RS485 communication (24 VDC type and 100 VAC type only). For details, see 4.3 Setting of parameters in 4. Operation Procedure.

It is recommended to perform the settings of the flow meter prior to installation.

2-1. Connection of battery

In the internal battery type, the battery is not connected upon shipment. Connect the battery connectors correctly in accordance with the following procedure before using the product.

- 1) Loosen the screws at the 4 locations shown in the figure and open the cover. (The screws cannot be removed from the cover to prevent them from dropping.)

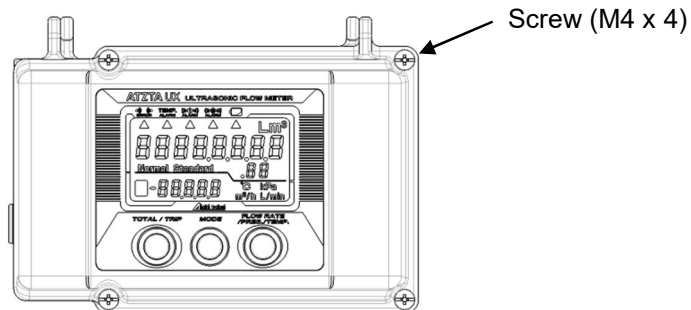

- 2) Connect the connectors of the battery and fix them to the hook of the battery pack.

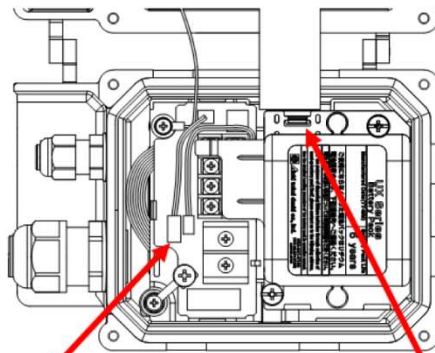

Fix the connectors to the **hook** of the battery pack.



Connect the connectors of the battery.

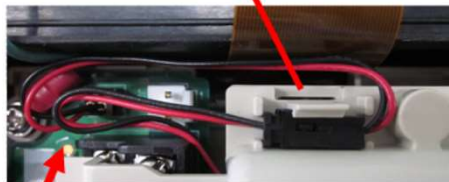

Install the lead wires as shown in the photo so that they will not be **caught** by the cover.

Note) If you use the product without fixing the connectors, it may cause a failure.

- 3) Check that the gasket fits in the gasket groove and close the cover. Close the cover carefully so that the earth wire and the lead wire of battery connector may not be caught by the cover

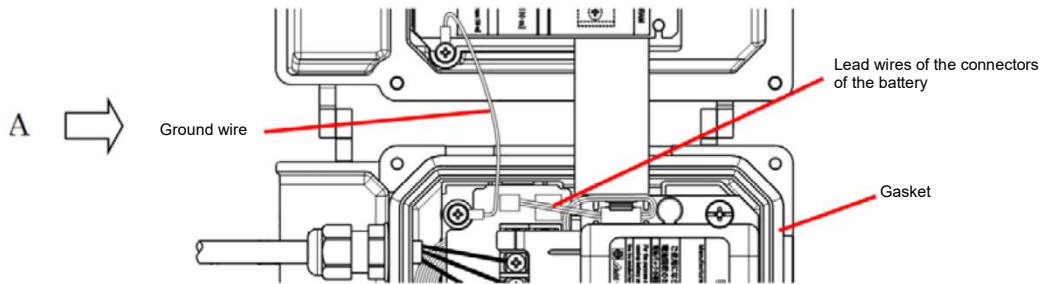

[Arrow A]

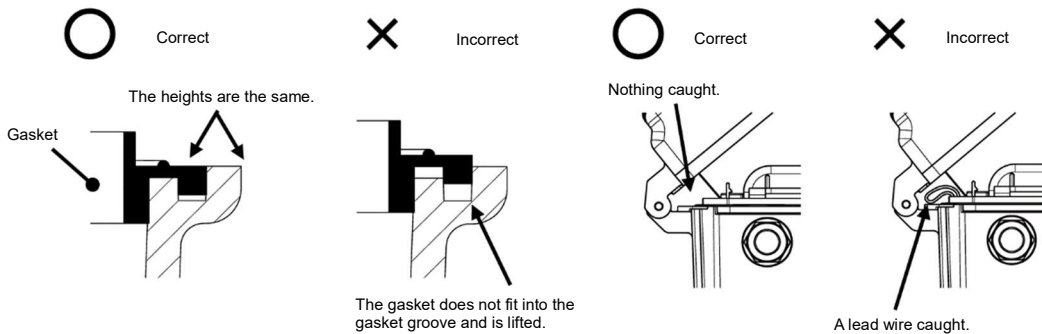

- 4) Tighten the screws at the 4 locations shown in the figure. Recommended tightening torque: $1.0 \pm 0.1 \text{ N}\cdot\text{m}$

Note) If the screws are not tightened enough or tightened with excessive torque, it may cause entry of water and/or breakage.

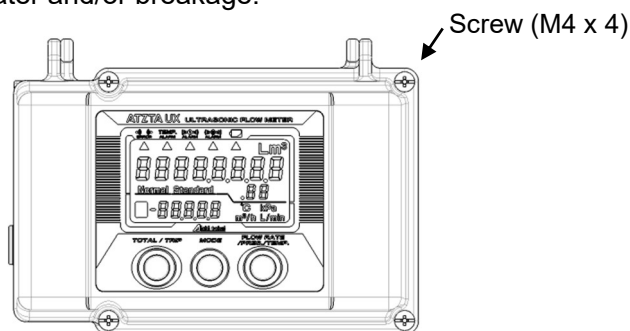

[About battery life expectancy and replacement of battery]

The expected life of the internal battery is 5 years. (This is the life expectancy under the standard conditions of temperature 20°C and humidity 65%RH. The actual life varies according to the installed environment (piping condition (near the governor, etc.) and temperature.)

This product contains a lithium battery, and therefore be sure not to dispose it in the general disposal route.

*For replacement of the battery, please contact your nearest branch or sales office.

2-2. Wiring connection

When you connect an external output cable or connect a cable for external power input in 24 VDC type and 100 VAC type, insert each cable into the section shown in the figure in accordance with the following procedure.

The GND (signal ground) is connected to the casing.

Utilize an isolated power supply or an external connection equipment, as necessary.

Note) Perform wiring connection of an external connection device in accordance with its operation manual.

[Reference] Max. cable length: 100 m

This is the operation range under our test conditions (VCTF, 0.3 sq). The operation range may change according to the installation environment, connection device, and cable type, etc.

Note that if you use a longer cable, signals may be attenuated, and noise is easily overlaid.

○ Procedure

- 1) Loosen the screws at the 4 locations shown in the figure and open the cover.
The screws cannot be removed from the cover to prevent them from dropping.

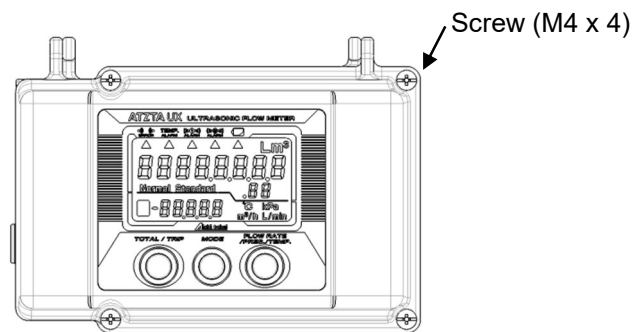

The state when the cover is opened varies according to the power supply type as shown below.

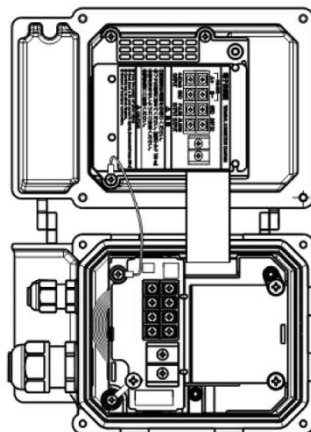

24 VDC type

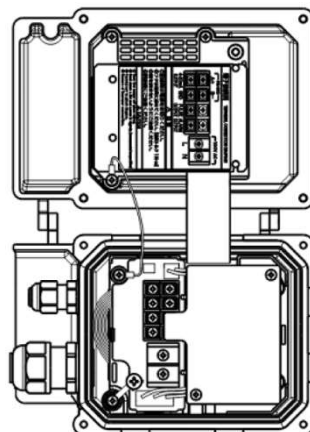

100 VAC type

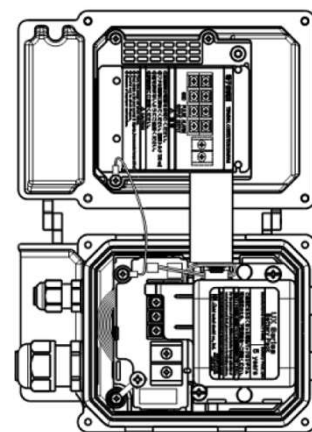

Internal battery type

Connect the cable.

- Procedure to connect the cable for external output
(When you do not connect the cable for external output, The procedure (1) to (4) are not required.
Applicable cable size: $\phi 4$ to 6.8 mm (Example: VCTF,0.3 sq,3 to 8 cores)
Terminal mount: M3

If you install the flow meter near an electric noise source, use a shield wire as a cable which is connected to the terminal block and ground the shield.
Applicable cable size : $\phi 4 \sim 6.8\text{mm}$ (MVVS 0.3sq 2-core to 6-core)

- [1] Loosen the sealing nut at the introductory part for an external output cable and pull out the pin. Be careful not to loosen the lock nut by mistake.

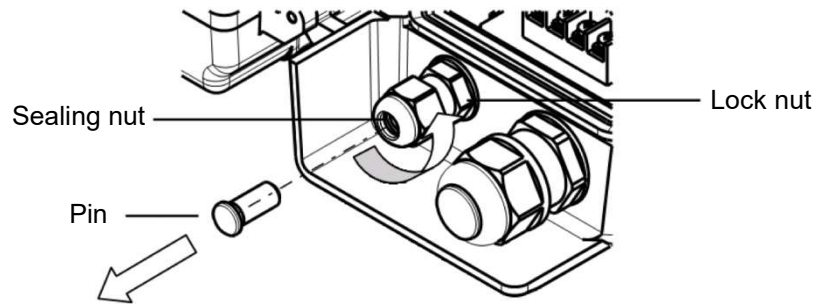

- [2] Insert the cable into the introductory part for the cable.

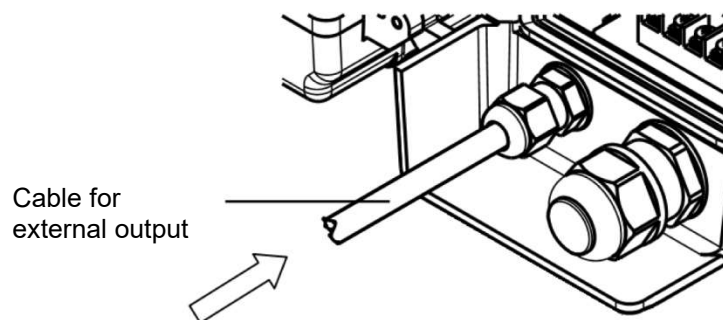

- [3] Make sure that the sheath of the cable gets into the inside of the case, crimp an applicable terminal on the cable, and connect the cable to the terminal block.

(Screw size: M3
Recommended tightening torque: $0.5 \pm 0.1 \text{ N}\cdot\text{m}$)

- * Note that incorrect wiring may cause a failure. Note that the usable terminal block varies according to the power supply type. (For the usage of each terminal mount, see “Terminal Connection Diagram” affixed inside of the cover or “Wiring Connection of Each Power Supply Type” on page 12 and 13.)

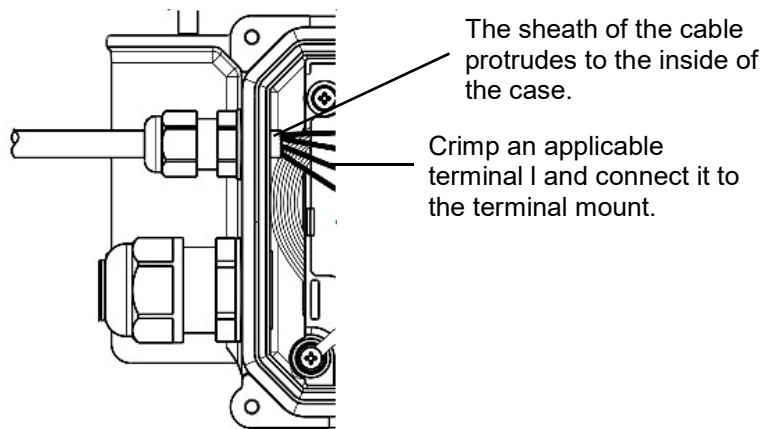

- [4] Tighten the sealing nut.
(Recommended tightening torque: $1.0 \pm 0.1 \text{ N}\cdot\text{m}$)

If a torque wrench is not available, the method of tightening the nut at appropriate torque is to manually tighten the sealing nut completely, or tighten it with a tool, and when you feel load, retighten it by 90° (= $1/4$ rotation). Do not tighten further. (Excessive torque may damage cables, break seal nut and cause entry of water due to seal deformation.)

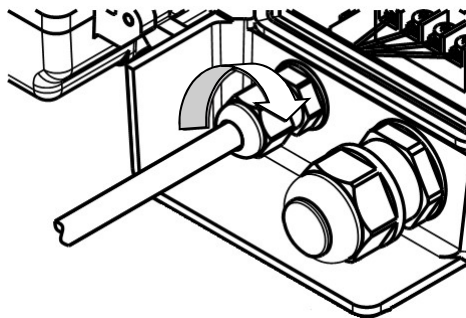

- Procedure to connect the cable for external power input
(When you do not connect the cable for external power input, the procedure (5) to (8) are not required.)

Applicable cable size: $\phi 6.5$ to 12.5 mm (Example: CV2sq2 core, CVV1.25sq2 core)

Terminal mount: M3 (in case of 24 VDC), M4 (in case of 100 VAC)

If you install the flow meter near an electric noise source, use a shield wire as a cable which is connected to the terminal mount and ground the shield.

- [5] Loosen the sealing nut at the introductory part for an external power input cable and remove the pin. Be careful not to loosen the lock nut by mistake.

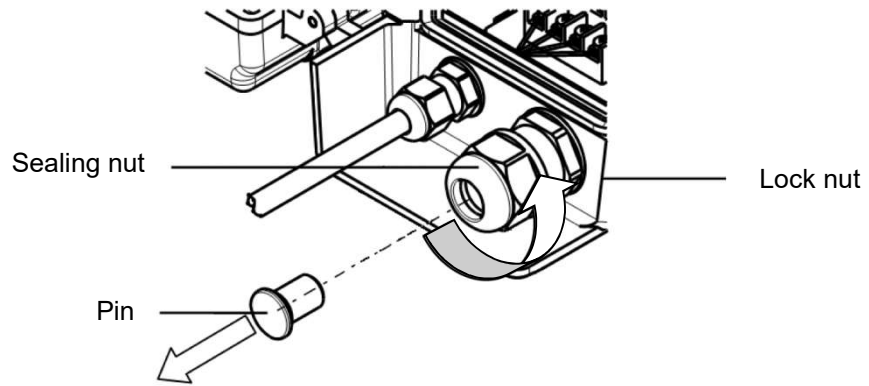

- [6] Insert the cable into the introductory part for the cable.

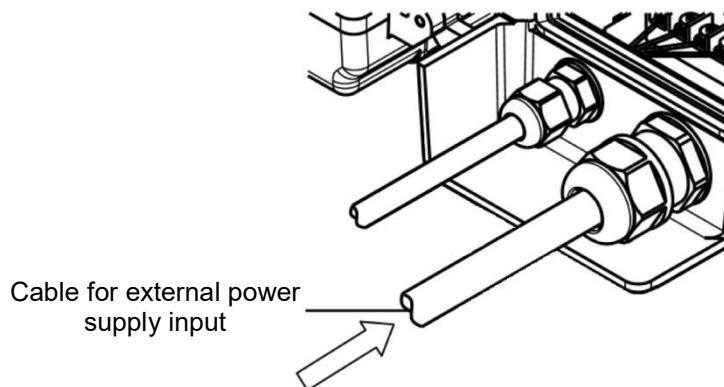

- [7] Make sure that the sheath of the cable gets into the inside of the case, crimp an applicable terminal on the cable, and connect the cable to the terminal block.

[In the case of 24 VDC type]

(Screw size: M3
Recommended tightening torque: $0.5 \pm 0.1 \text{ N}\cdot\text{m}$)

[In the case of 100 VAC type]

(Screw size: M4
Recommended tightening torque: $1.0 \pm 0.1 \text{ N}\cdot\text{m}$)

Note) The cover of the terminal mount is removed at the time of wiring connection. Be sure to restore it after wiring connection is finished.

- * Note that incorrect wiring may cause a failure. Note that the usable terminal mount varies according to the power supply type. (For the usage of each terminal mount, see “Terminal Connection Diagram” affixed inside of the cover or “Wiring Connection of Each Power Supply Type” on page 12 13.)

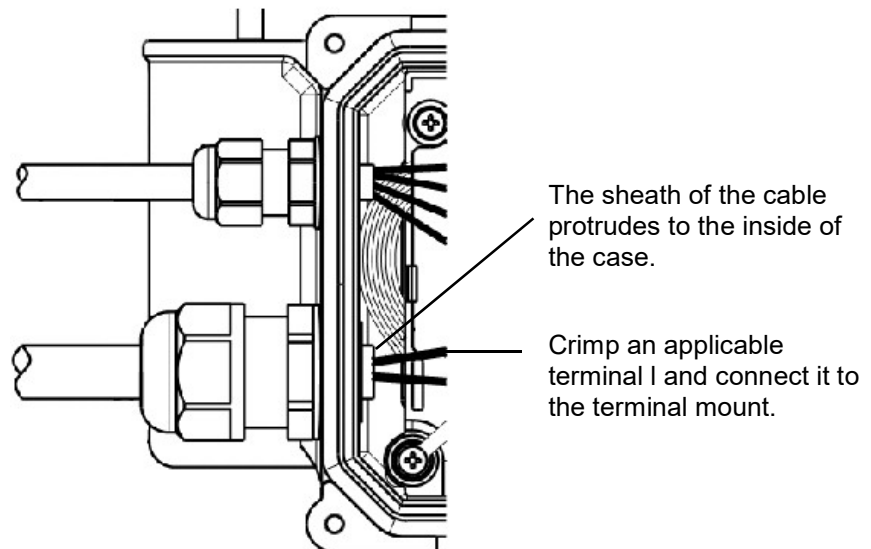

- [8] Tighten the sealing nut.
 (Recommended tightening torque: $1.5 \pm 0.1 \text{ N}\cdot\text{m}$)

If a torque wrench is not available, the method of tightening the nut at appropriate torque is to manually tighten the sealing nut completely, or tighten it with a tool, and when you feel load, retighten it by 90° (= 1/4 rotation). Do not tighten further. (Excessive torque may damage cables, break seal nut and cause entry of water due to seal deformation.)

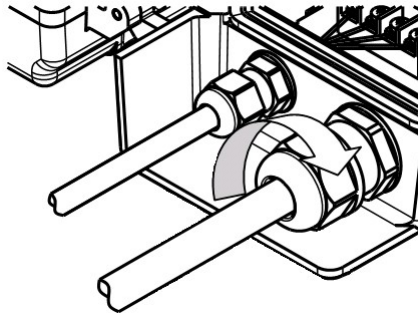

- 2) Check that the gasket fits in the gasket groove and close the cover.
 Close the cover carefully so that the earth wire and the lead wire of battery connector may not be caught by the cover.

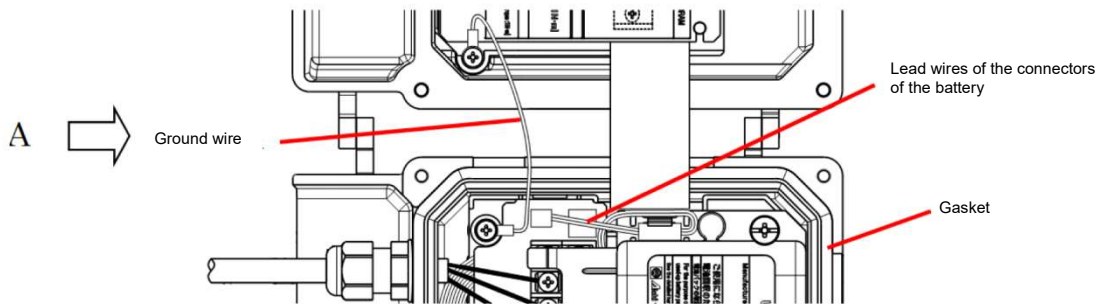

[Arrow A]

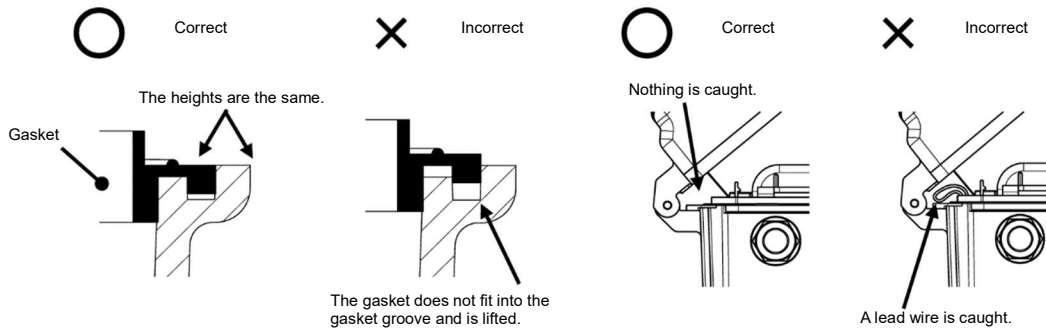

3) Tighten the screws at the 4 locations shown in the figure.

(Recommended tightening torque: $1.0 \pm 0.1 \text{ N}\cdot\text{m}$)

Note) If the screws are not tightened enough or tightened with excessive torque, it may cause entry of water and/or breakage.

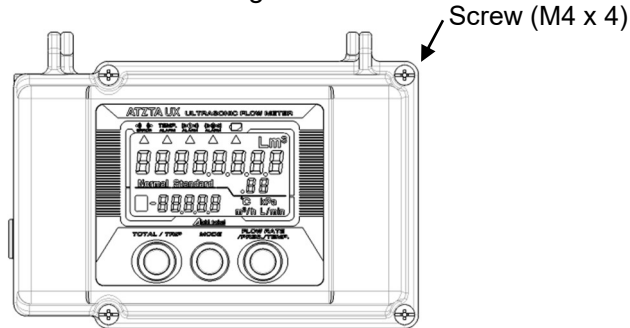

“Wiring Connection of Each Power Supply Type” is shown below.

For the usage of each terminal block, see “Terminal Connection Diagram” affixed inside of the cover.

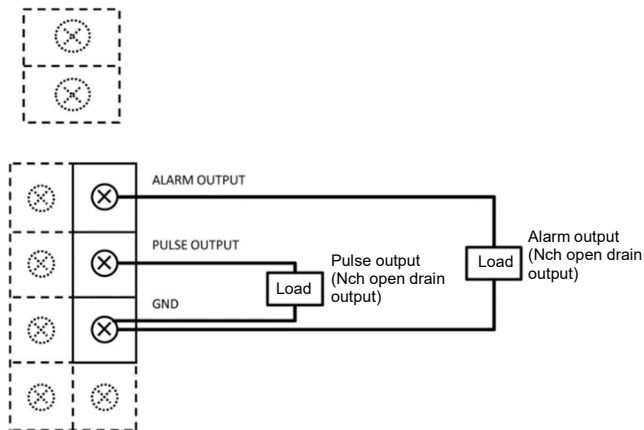

Fig.1 Wiring Connection [Internal Battery Type]

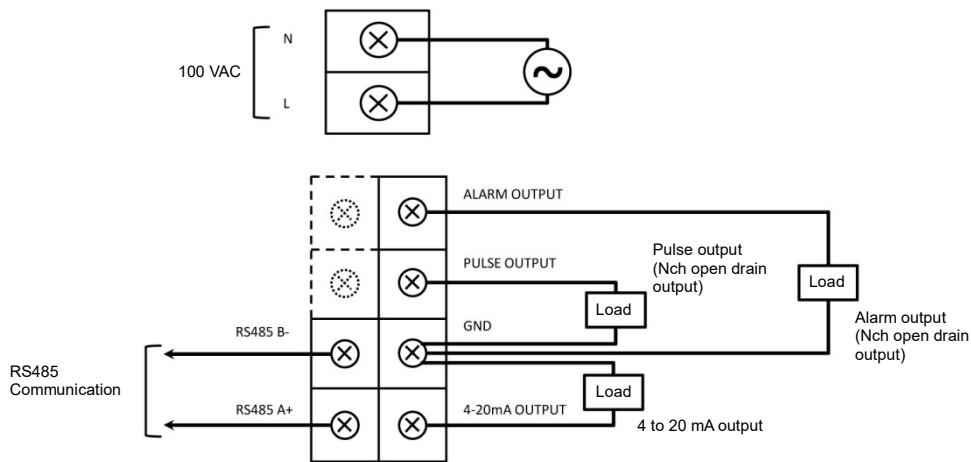

Fig 2. Wiring Connection [100 VAC Type]

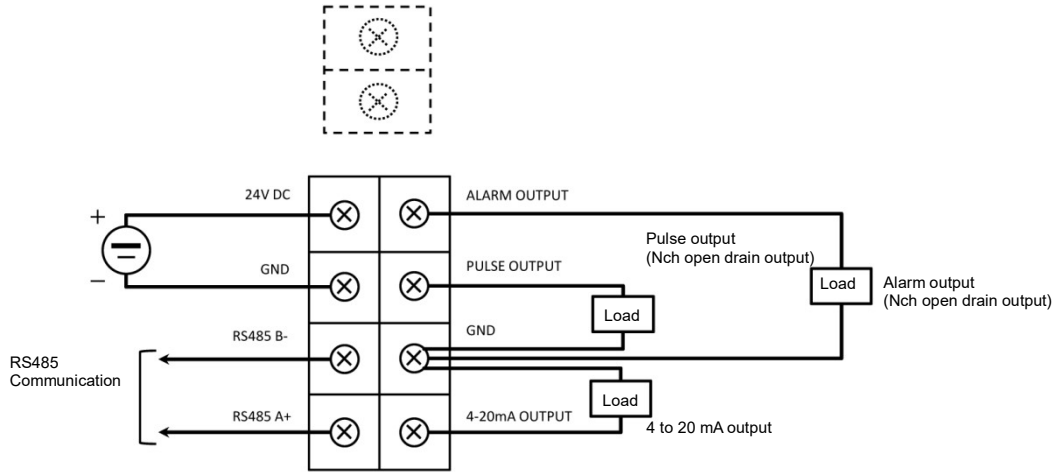

Fig.3 Wiring Connection [24 VDC Type]

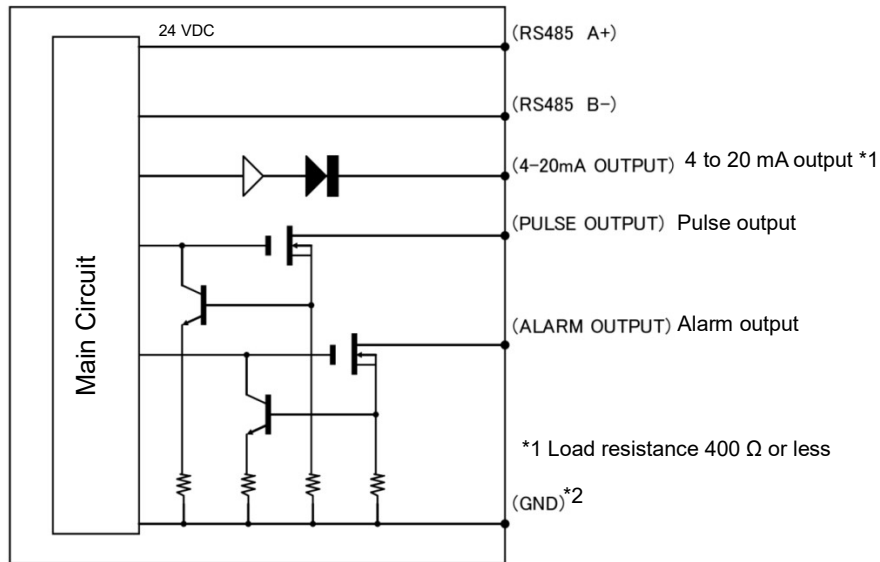

Fig.4 Input/Output Circuit Diagram

*2 The GND (signal ground) is connected to the casing.

Take the following measures, as necessary.

- For DC24V type, use an insulation type power supply.
- Install a pulse isolator to isolate signals between the flow meter and a receiver.
- Use an insulating bolt, insulating washer, etc., to isolate the casing and pipes.

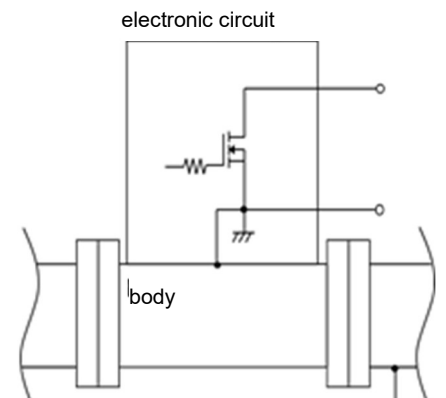

Fig. 4-2 Relationship of the casing and the GND (signal ground) (Example: Pulse output)

2-3. Installation

Match the arrow on the meter with the forward flow direction of the fluid.

This product can be installed indoors or outdoors, and on either horizontal or vertical piping. Installation in which the display part faces downward and the cable introduction part faces upward cannot be performed.

It is recommended to use rising piping to install the flow meter if the air contains oil mist, dust, or other materials. If oil mist and/or dust accumulates inside this product, it may cause performance failure and/or defects.

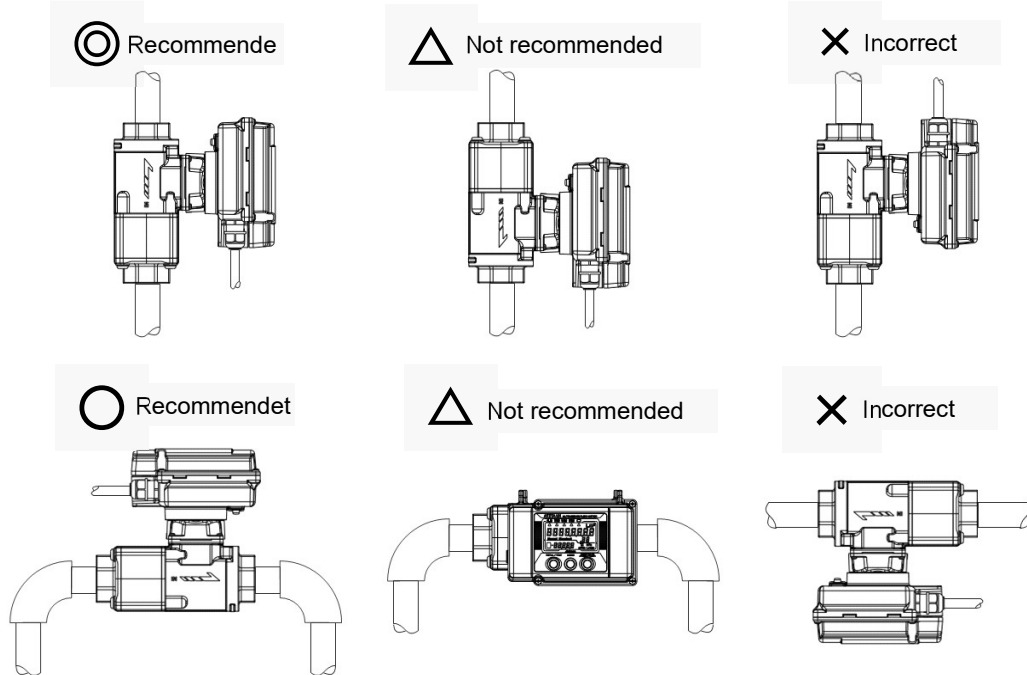

The figure below shows the recommended lengths of the straight pipe sections according to the piping condition for this flow meter. (D: Nominal diameter)

Piping condition	Upstream	Downstream
Elbow	<p>0D or longer (Straight pipe section is not required.)</p> <p>Elbow</p>	<p>0D or longer (Straight pipe section is not required.)</p> <p>Elbow</p>
Flexible pipe	<p>0D or longer (Straight pipe section is not required.)</p> <p>Flexible pipe</p>	<p>0D or longer (Straight pipe section is not required.)</p> <p>Flexible pipe</p>

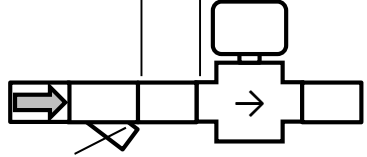
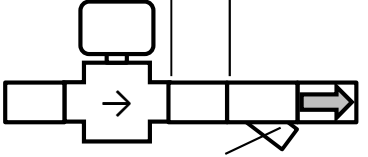
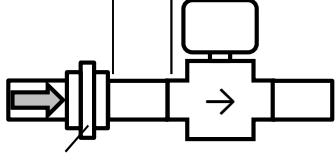
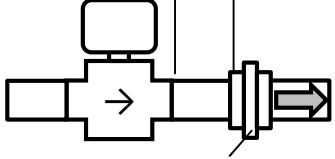
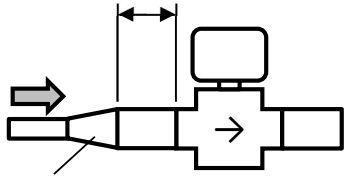
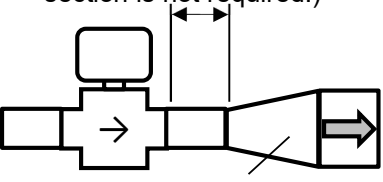
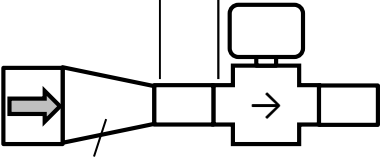
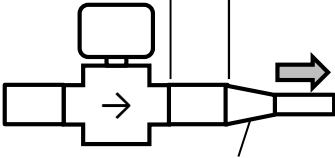
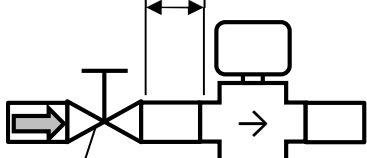
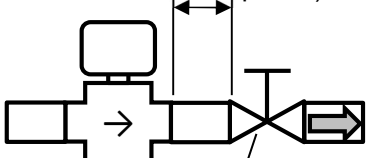
Condition	Upstream	Downstream
Y-shaped strainer	<p>0D or longer (Straight pipe section is not required.)</p>  <p>Y-shaped strainer</p>	<p>0D or longer (Straight pipe section is not required.)</p>  <p>Y-shaped strainer</p>
Union joint	<p>0D or longer (Straight pipe section is not required.)</p>  <p>Union joint</p>	<p>0D or longer (Straight pipe section is not required.)</p>  <p>Union joint</p>
Enlarge pipe (Up to 2 openings)	<p>1 opening: 0D or longer (Straight pipe section is not required.) 2 openings: 5D or longer</p>  <p>Enlarge pipe</p>	<p>0D or longer (Straight pipe section is not required.)</p>  <p>Enlarge pipe</p>
Narrowing pipe	<p>0D or longer (Straight pipe section is not required.)</p>  <p>Narrowing pipe</p>	<p>0D or longer (Straight pipe section is not required.)</p>  <p>Narrowing pipe</p>
Valve (Flow-rate is adjusted by valve.)	<p>5D or longer</p>  <p>Valve</p>	<p>0D or longer (Straight pipe section is not required.)</p>  <p>Valve</p>

Piping condition	Upstream	Downstream
Governor	<p>10D or longer</p> <p>Governor</p>	<p>10D or longer</p> <p>Governor</p>
Tee pipe	<p>20D or longer</p> <p>Tee pipe</p>	<p>0D or longer (Straight pipe section is not required.)</p> <p>Tee pipe</p>

This product does not have a complete waterproof structure (IP64). Do not install it at a place that may be submerged in water.

If the flow meter is exposed to direct sunlight, providing a sunshade or using the optional cover is recommended.

Screw on the tapered threads for piping using the torques shown below.

UX25s: 100 N•m

UX50: 120 N•m

Prevent the entry of foreign materials in piping, such as weld chips, dust, sealing tape and sealant such as weld chips, dust, sealing tape, and sealant do not make their way into the pipes.

In the case of new piping, install the product after sufficient cleaning of the pipe(s).

Do not install the flow meter in sections where it will be subjected to significant compression forces, tensile loads, and other loads after it is installed.

Do not drop the product, hit it, or apply excessive impact.

The display section can be rotated to change its orientation. To change the display's orientation, loosen the set screw at the neck section of the display using an M4 hex wrench and then rotate the display section. Once it is in the desired orientation, always make sure to tighten the set screw to fix the display section in place.

When turning the display unit, do not apply force to any direction other than the rotational direction. (Applying such force may cause a failure.)

A feeling of being stuck or unsmooth rotation during the rotation is indication of possibility that force is being applied in a direction other than the direction of rotation. In the case, stop applying force once and check if force direction and the way of rotation are correct.

- * The display section can be rotated by 180° clockwise and 90° counterclockwise in the flow direction L (left to right of the display section) as seeing from the display side. It cannot be rotated more than the rotation range.

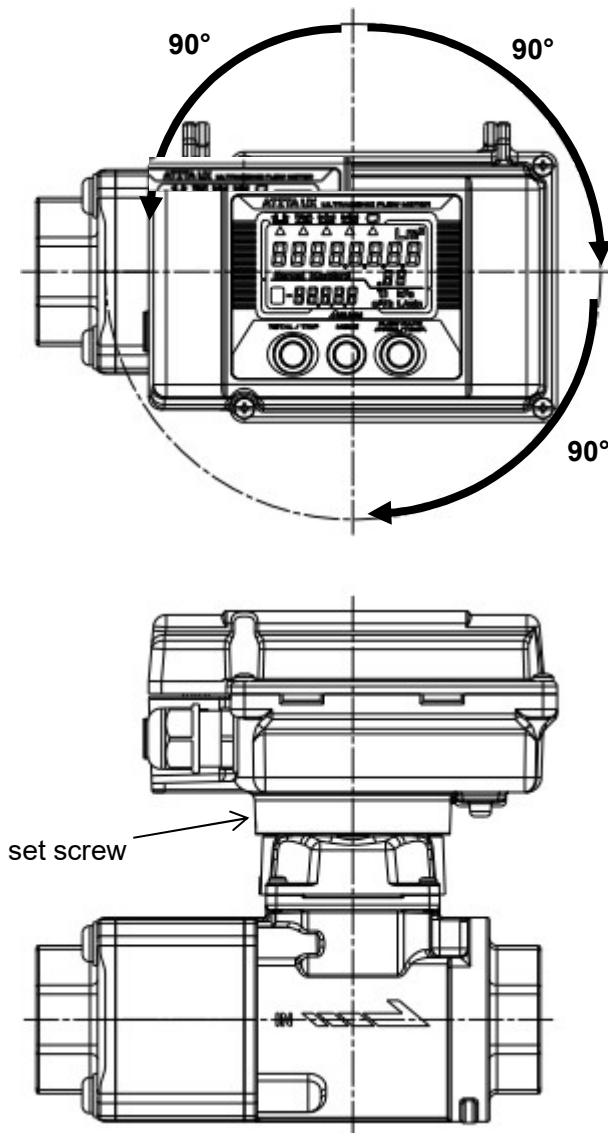

3.Start up procedure

After the subject fluid for measurement is set, turn on the power while no fluid flows (0 m³/h).

3-1.When the power is turned on

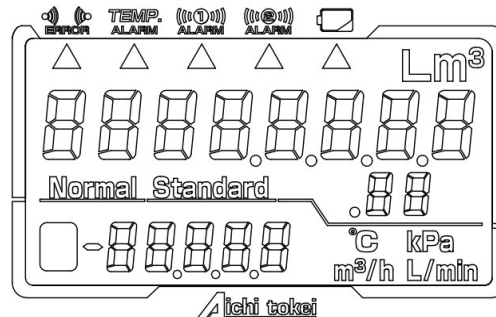

When the power is turned on, check that the entire LCD is turned on, and the symbols and units flicker every 2 sec.

The display is switched to the measurement mode in approx. 1 min.

If it is not switched to the measurement mode, the conceivable causes are as follows:

3-1-1.Abnormal in ultrasonic measurement

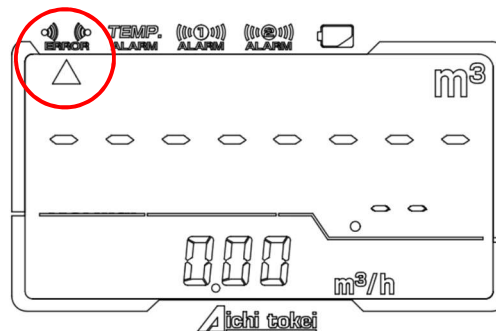

Check that there is no foreign material which prevents transmission of ultrasonic in the pipe and that oil and other fluid are not affixed and stationed in the pipe, and then turn on the power again.

When “Abnormal in ultrasonic measurement” is displayed even if no foreign material is affixed and/or stationed, please contact the company you purchased the product from or our branch or sales office.

3-1-2. Abnormal temperature value

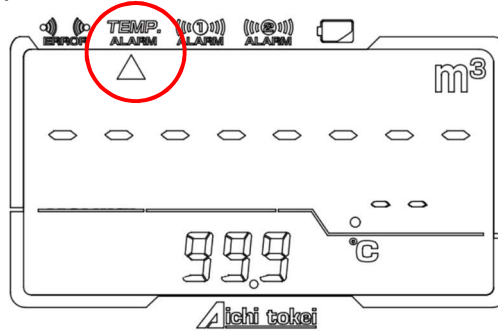

Check that the temperature in the pipe is within the specifications, and then turn on the power again. When “Abnormal temperature value” is displayed even if the temperature value is correct, please contact the company you purchased the product from or our branch or sales office.

3-1-3. Aberrant pressure value

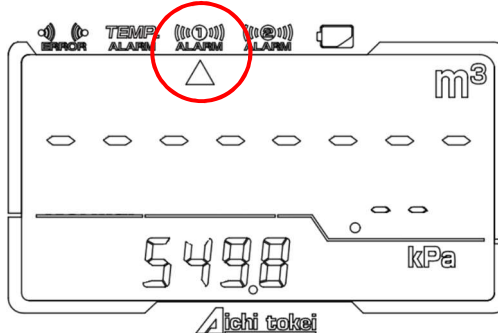

Check that the pressure in the pipe is within the specifications, and then turn on the power again. When “Aberrant pressure value” is displayed even if the pressure value is correct, please contact your nearest branch or sales office.

3-2. When operation starts

When you are running the meter for the first time, gradually open the valve and check that the pilot lamp is flickering. A flickering pilot lamp indicates that the fluid is flowing.

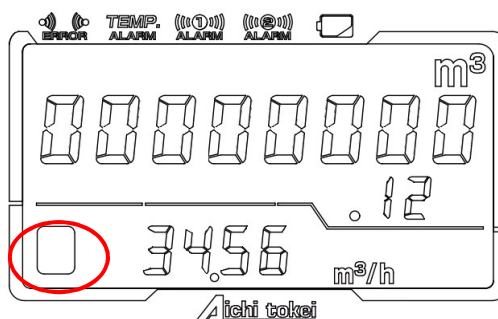

4. Operation Procedure

This product consists of the preliminary measurement mode, measurement mode, settings mode, and test mode.

Using the 3 buttons, you can switch the modes and displays, and make various local settings.

For arrangement of the left button, center button, and right button, see Fig 5.

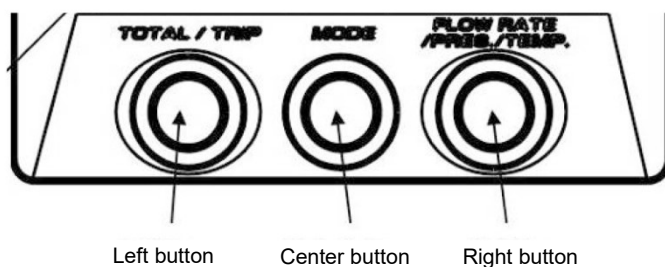

Fig 5. Button arrangement

For button operations for each operation mode, follow the table below.

Table 1 Button operation for each mode

Position and name of button		Preliminary measurement mode	Measurement mode	Setting mode		Test mode
Button position	Name			Local setting display	Detailed setting	
Left	SW1		Switchover between total accumulated flow volume and trip accumulated flow volume	Switchover to the next setting item	Switchover of setting contents Change of the flickering digit	
Right	SW2		Switchover between instantaneous flow-rate [m ³ /h], pressure ³⁾ , and temperature. Switchover to test mode*	Switchover to the previous setting item	Change of the value at flickering digit.	Switchover to measurement mode*
Center	SW3		Switchover to setting mode	Switchover to measurement mode		
	SW1 + SW2 ¹⁾	Completion of replacement of battery*	Clearing of trip accumulated flow volume ²⁾	Switchover between local setting and detailed setting		

- 1) "SW1+SW2" denotes steps where both switches must be pressed simultaneously.
- 2) By pressing SW1 and SW2 simultaneously while the trip accumulated flow volume is displayed, the trip accumulated flow volume can be cleared.
- 3) The operating gas pressure setting value is displayed in the type without pressure sensor, and the measured pressure is displayed in the type with pressure sensor.

* You need to press the switches for 3 sec or more.

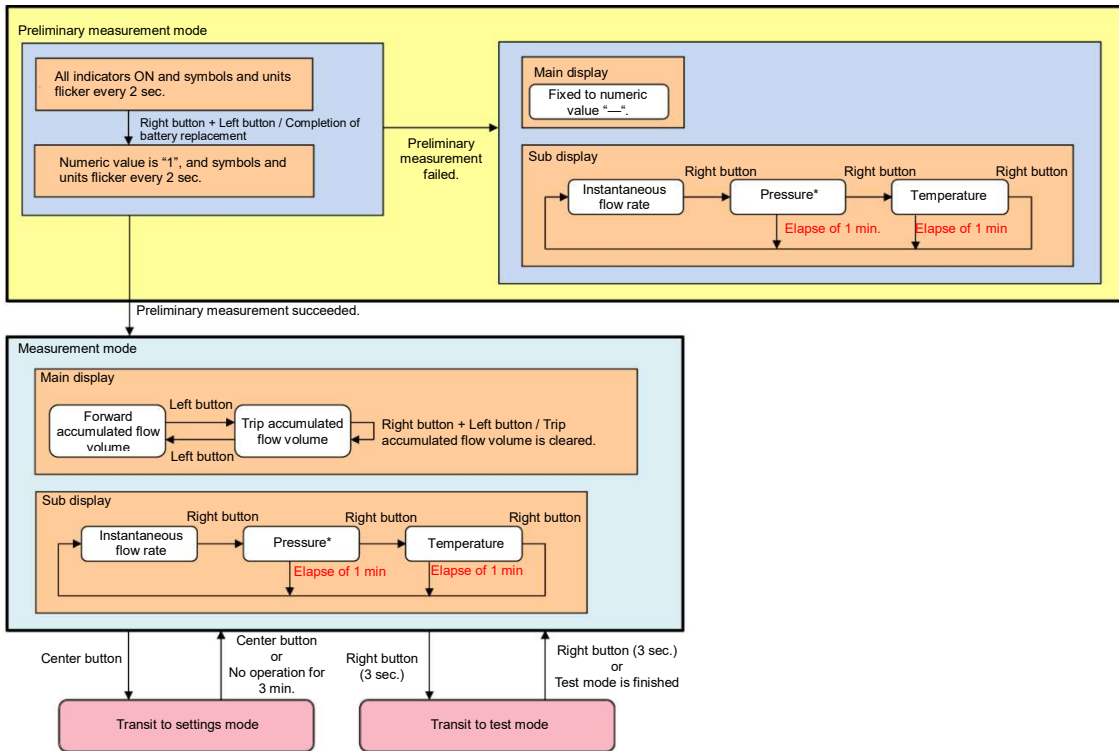

* "Pressure" in sub display: The operating gas pressure setting value is displayed in the actual Type without pressure sensor, and the measured pressure is displayed in the conversion Type with pressure sensor.

Fig. 6 Button operation in measurement mode and switchover to each mode

4-1. Display of measurement values (measurement mode)

4-1-1. Conversion display

The partition line varies according to the conversion setting.

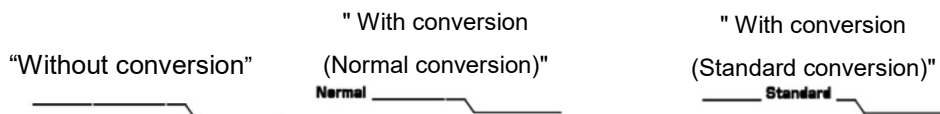
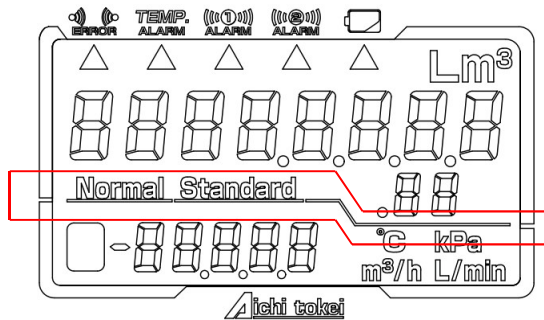

4-1-2. Display of accumulated flow volume

The number of digits displayed varies according to the conversion setting.

[Total accumulated flow volume] 00000000.00 (m³) 8 integers and 2 decimal places

[Trip accumulated flow volume] 0000000.00 (m³) 7 integers and 2 decimal places

Every time you press the left button, the trip accumulated flow volume and total accumulated flow volume are displayed in turn in the main display.

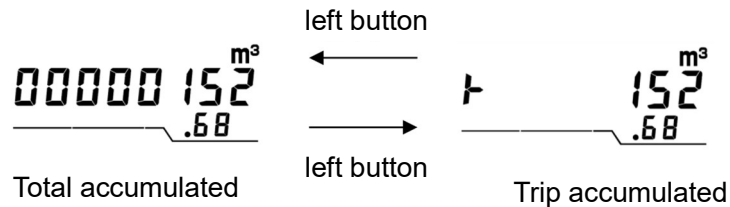

By pressing the left button and right button simultaneously while the trip accumulated flow volume is displayed, the trip accumulated flow volume is cleared.

If the trip accumulated flow volume exceeds 9999999.99, 0000000.00 is displayed without zero suppress, and the accumulation operation continues.



(Trip accumulated flow volume 10000152.68 [Normal·m³])

4-1-3. Display of instantaneous flow-rate, temperature, pressure

The number of the display digits of each item is shown below.

[Instantaneous Flow-rate]

(Less than 1000) 000.00 (m³/h) 3 integers and 2 decimal places
 (1000 or more) 0000.0 (m³/h) 4 integers and 1 decimal place

[Temperature]

00.0 (°C) 2 integers and 1 decimal place

[Pressure]

(Type without pressure sensor) 000.00(kPa) 3 integers and 2 decimal place
 (The operating gas pressure setting value is displayed.)
 (Type with pressure sensor) 0000.0(kPa) 4 integers and 1 decimal place
 (The measured pressure value is displayed.)

- * The content of the pressure display is different between the type without pressure sensor and type with pressure sensor.
 Type without pressure sensor: Operating gas pressure setting value (The partition line is turned off.)
 Type with pressure sensor: Measurement value (The partition line is turned on.)

Every time the right button is pressed, the sub display will cycle from Pressure to Temperature and then to instantaneous flow-rate.
 One minute after pressure or temperature is displayed, the display will automatically transit to the instantaneous flow-rate display.

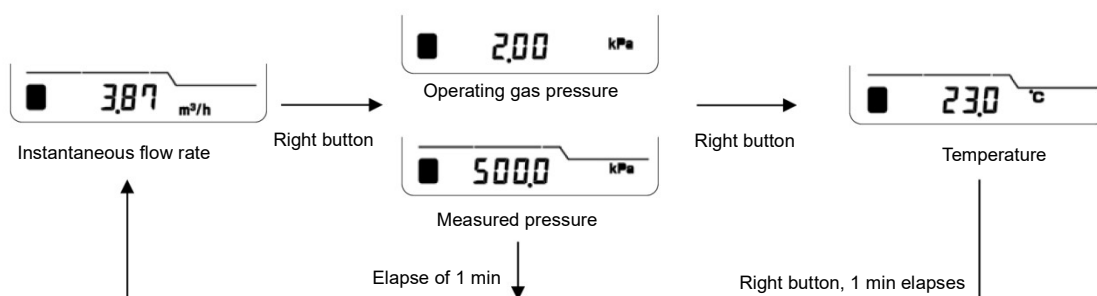

4-2.Measurement of very small flow-rate (Test mode time selection)

The test mode is a function to temporarily cancel the low flow cutoff.
Please use the test mode under conditions where there is no flow.

You can transit to the test mode by pressing the right button for 3 seconds in the measurement mode, and this will allow you to measure very small flow-rates. In the test mode, the units in the sub display ("m³/h", "kPa", "°C") flicker every 0.5 sec. You can select 3 min, 60 min, or unlimited as the test mode time, and when the specified time elapses, the mode will automatically transit to the measurement mode. The mode will transit to the measurement mode if the right button is pressed for 3 seconds or longer again in the test mode.

If the flow-rate value in the instantaneous flow-rate display is (+) 0.01 or larger, or the pilot lamp is flickering, there is a possibility of a leakage at the downstream of the meter. If "-" (minus) is displayed in the instantaneous flow-rate display, there is a possibility of a leakage* at the upstream of the meter.

- * Possibility of leakage: Please note that this is strictly a possibility as the displayed value also includes zero flow-rate offset, internal convection and other factors. The instantaneous flow-rate display in test mode is rounded off to the second decimal point.

Examples) Measurement value: 0 to 0.004 [m³/h] -> Display: 0.00 [m³/h]
Measurement value: -0.004 to 0 [m³/h] -> Display: -0.00 [m³/h]

4-3.Setting of parameters (Settings mode)

Press the center button, and you will transit to the settings mode. If you press the center button again, you will transit from the settings mode to measurement mode. If no operation is performed in the settings mode for 3 minutes, the mode will automatically transit to the measurement mode.

In the settings mode, you can change the settings explained in Table 4 Setting items and settings in Settings mode (page33).

For button operation in the settings mode, see Display Switchover Diagram in the settings mode Fig. 7 to 9 (page 44 to 46).

- * The same settings can be made via RS485 communication. Make settings via RS485 communication under conditions where button operations may be difficult, such as when the flow meter is used at heights. Refer to communication specifications "TS-UX-003-TG" for details on the communication features.

You can download the communication specifications from our web site.

5. Alarm Display

In the alarm display, “▲” corresponding to the applicable alarm is turned on.

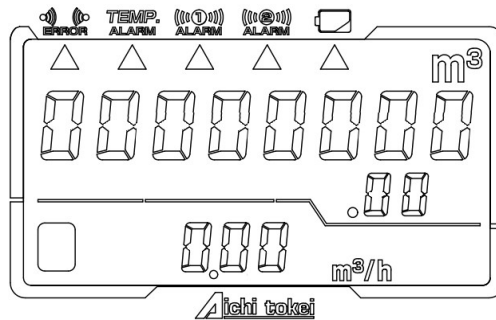

5-1. Abnormal ultrasonic measurement

When the ultrasonic signal is small and cannot be received, “Abnormal ultrasonic measurement” is turned on, and “0.00” is displayed as the instantaneous flow-rate value.

The accumulation stopped as the accumulated flow volume value just before the error occurred remains displayed, and 1 mA is output as analog output.

Check that there is no foreign material which prevents transmission of ultrasonic and/or oil and other fluid are not affixed in the pipe. When “Abnormal ultrasonic measurement” is turned on even if no foreign material is affixed and/or stationed, please contact your nearest branch or sales office.

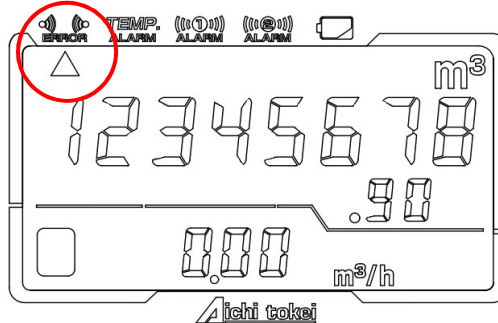

(Note) Actions when the meter is first run

At the time of installation and start of operation of the flow meter, there are cases where “Abnormal ultrasonic measurement” is turned on due to excessive flow and/or mixture of air and gas upon conversion of air into gas. After conversion is completed and the fluid is stabilized, “Abnormal ultrasonic measurement” will be turned off. (This is not an error.)

5-2. Battery replacement alarm [Internal Battery Type]

When 5 years pass after the battery connector is connected (the power is turned on), including storing period, “battery replacement alarm” is turned on to inform the user that it is time to replace the battery. While measurement continues even after “battery replacement alarm” is turned on, it is recommended to replace the battery as soon as possible when “battery replacement alarm” is turned on.

When you replace the battery, contact your nearest branch or sales office.

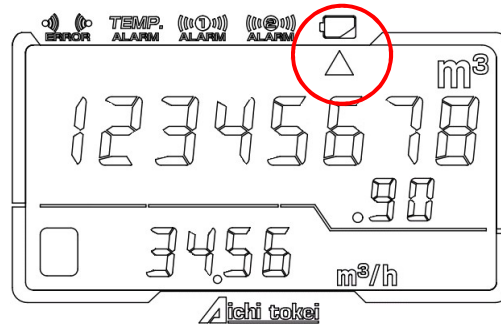

When the remaining battery becomes low after “battery replacement alarm” is turned on, the accumulated volume flickers every 0.5 sec as showing the battery is approaching to the end of life. The measurement operation is stopped, “0.00” is displayed as the instantaneous flow-rate display, and the accumulation is stopped as the accumulated flow volume value just before the alarm is turned on.

Replace the battery immediately.

When you replace the battery, contact your nearest branch or sales office.

The battery life is 5 years or more under the normal condition, but the end of the battery may be displayed within 5 years according to the environment temperature.

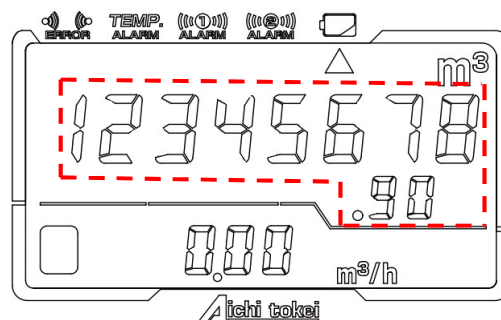

In this state, you can switch the total accumulated flow volume display and trip accumulated flow volume display using the left button, and switch the instantaneous flow-rate, temperature, and pressure display using the right button, but you cannot switch the mode to the settings mode using the center button.

5-3. Abnormal temperature value

When an error of the temperature value is detected, “Abnormal temperature value” is turned on. When an error of the temperature value is detected, “0.00” is displayed as the instantaneous flow-rate, an abnormal value is displayed as the temperature, and 1 mA is output as the analog output. As for the accumulated flow volume value in the main display, the accumulation process stops and the display shows the value immediately prior to the abnormality.

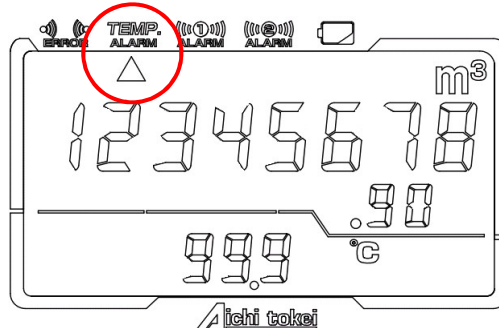

5-4. Abnormal pressure value (Type with pressure sensor)

When an error of the pressure value is detected, “Abnormal pressure value” is turned on. When an error of the pressure value is detected, “0.00” is displayed as the instantaneous flow-rate, an abnormal value is displayed as the pressure value, and 1 mA is output as the analog output. As for the accumulated flow volume value in the main display, the accumulation process stops and the display shows the value immediately prior to the abnormality.

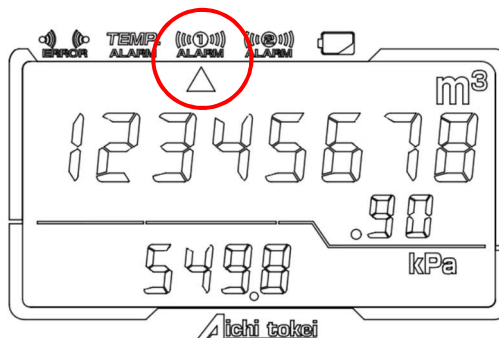

5-5. Abnormal compensation (Type without pressure sensor)

When an error is detected inside flow-rate compensation, “Abnormal compensation” is turned on. When an error is detected, “0.00” is displayed as the instantaneous flow-rate, and 1 mA is output as the analog output. As for the accumulated flow volume value in the main display, the accumulation process stops and the display shows the value immediately prior to the aberration.

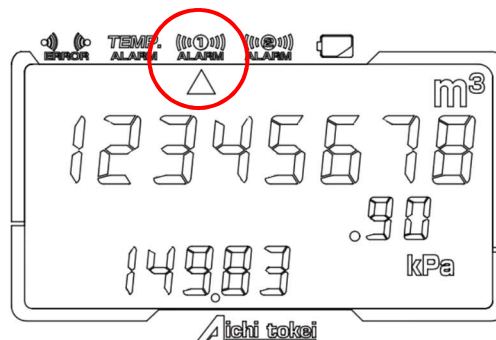

5-6.External memory abnormality

When abnormality data is detected upon recovery of the accumulated value when the power is turned on by setting of communication or button operation, and external power supply type (24 VDC, 100 VAC), “External memory aberration” is turned on. When “External memory abnormality” is turned on, check and reset the setting value. If “External memory abnormality” is not turned off even after all the data is reset, there is a possibility of a failure. Please contact the company you purchased the product from or our branch or sales office.

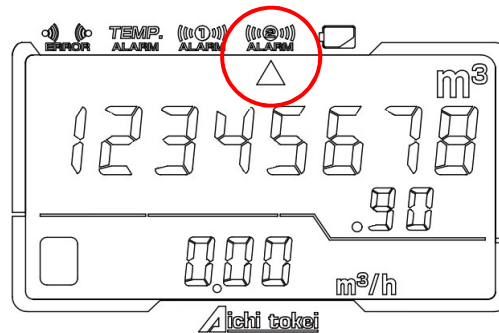

When an error of internal data is detected, the accumulated flow volume flickers every 0.5 sec.

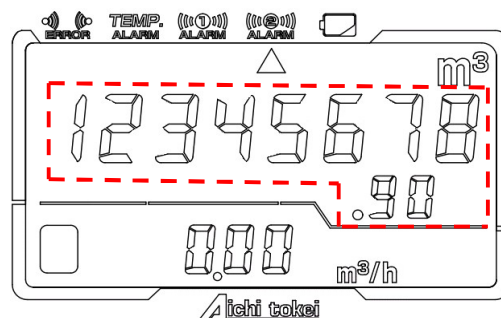

There is a possibility of a failure. Please contact the company you purchased the product from or our branch or sales office



5-7.In the case of power outage (DC type, AC type)

- Power outage detection
When the power supply voltage is dropped to 18 ± 1.1 V or lower, the meter determines a power outage, stops the measurement, and turns off the LCD.
- Recovering from a power outage
When the power supply voltage recovers to 18.8 ± 1.1 V or greater, the meter resumes the measurement and turns on the LCD.
The accumulated flow volume and trip accumulated flow volume are saved every 5 minutes after the power is turned on. When the flow meter recovers from a power outage, the accumulated flow volumes saved just before a power outage occurs are restored, and accumulation is performed using these values.
When the flow meter recovers from a power outage, the accumulated flow volumes are displayed in the upper LCD.

6. Troubleshooting

Timing	Phenomenon	Possible cause	Remedial action
Immediately after installation	Abnormal ultrasonic measurement  " is turned on. (See page 18 and 25.)	Gas replacement operation is underway.	When the replacement operation is finished, ultrasonic measurement abnormal is turned off.
		The meter is used outside the range of the specifications (such as installation conditions, gas type, pressure, and temperature).	Check that the safety concerns and specifications [page 30] are complied with.
		There is a major source of electrical noise near the flow meter.	Take a measure to eliminate the noise source or shield the flow meter. Use a shield wire as a cable which is connected to the terminal mount and ground the shield.
	The flow meter does not start accumulation immediately after installation.	Gas replacement operation is underway.	Check to see if the partition line between the main and sub-displays is flickering. When the replacement operation is finished, accumulation starts.
	The instantaneous flow-rate shows a negative value.	The direction of the fluid flow and the flow direction of the meter are opposite of each other.	Check to see that the arrow on the surface of the flow meter is pointing in the direction of the fluid flow.
During operation	Battery replacement alarm  " is turned on. (See page 28).	The internal battery needs to be replaced.	It indicates the necessity to replace the internal battery. (Contact your nearest Aichi Tokei Denki branch or sales office.)
	The accumulated flow volume flickers.	The battery reaches its life expectancy.	It indicates that the internal battery reaches its life expectancy. (Contact your nearest Aichi Tokei Denki branch or sales office.)
		Internal memory aberration occurs.	It indicates the possibility of an internal memory failure. (Contact your nearest Aichi Tokei Denki branch or sales office.)
	The instantaneous flow-rate appears to be fluctuating.	The pressure fluctuates frequently.	The flow meter operates correctly. Installation of the meter in a place where there is little change in pressure is recommended to make accurate measurements.
		There is pulsation.	The flow meter operates correctly. Installation of the meter in a place where there is little pulsation is recommended to make accurate measurements.
		The meter is used outside the range of the specifications (such as installation conditions, gas type, pressure, and temperature).	Check that the safety concerns and specifications [page 30] are complied with.
	The instantaneous flow-rate does not fall to zero even there is no flow.	Gas is convecting in the pipe.	The flow meter operates correctly.
		Test mode is on.	When the units in the sub display flicker, the test mode is on. Turn it off according to need. (See Test mode [page 24].)
		The meter is used outside the range of the specifications (such as installation conditions, gas type, pressure, and temperature).	Check that the safety concerns and specifications [page 30] are complied with.
	The instantaneous flow-rate is too large.	"Conversion flow rate (Normal or Standard)" display is set.	Check to see that the correct value unit for the application is used. (For how to change the unit, see Setting of flow meter [page 38].)
	The instantaneous flow rate does not seem to change.	There is excessive flow rate larger than the specifications.	Use the meter within the scope of its specifications. (For the specifications, see [page 30].)
		Adjustment of ultrasonic measurement is underway.	The flow meter operates correctly. This should typically complete in about 30 seconds.
	The instantaneous flow rate is too small.	The display shows the "Actual flow-rate (m ³)".	Check to see that the correct value unit for the application is used. (For how to change the unit, see Setting of flow meter [page 38].)
There is no "0" displayed in the upper digit of the accumulated flow volume.	The display shows the trip accumulated flow volume.	The flow meter operates correctly. (For how to restore the forward accumulated flow volume, see the operation of the display section [page 20].)	

7.Specifications

7-1.List

UX [Nominal diameter] / [Pressure] [Power supply] / [Flow direction] / [Gas type]

Model		UX25s	UX32
Connection of pipe		Screw connection	
		Rc1	Rc1 · 1/4
Maximum operating pressure		100 kPa	
Gas type for measurement		City gas (13A), butane (butane 70%, propane 30%), propane (propane 98%, butane 2%), nitrogen, argon	
Power supply/ Power consumption	Battery	Dedicated lithium battery (5-year life expectancy under 20°C and 65%RH)	
	AC power supply	100 VAC ± 15% / 10 W or less (when analog output is 22 mA)	
	DC power supply	24 VDC ± 10% / 2 W or less (when voltage is 26.4 V and analog output is 22 mA)	
Flow-rate range (actual flow-rate) ^{*1)}		+0.7 to +35m ³ /h	
Accuracy	Minimum flow rate Q _{min} ~ Transitional flow rate Q _t	① ±0.5%FS	+0.7 to +3.5m ³ /h
	Transitional flow rate Q _t ~ Maximum flow rate Q _{max}	② ±4.0%RD <small>*5)</small>	+3.5 to +35 m ³ /h
Compensation of temperature/pressure		Disabled/Enabled (Normal/Standard conversion)	
Conversion accuracy		±1.5% RD (At 23°C and 100 kPa)	
Display	Main display section	Accumulated flow : 8 integers and 2 decimal places volume Trip accumulated flow : 7 integers and 2 decimal places volume Ultrasonic measurement abnormal, temperature measurement abnormal, pressure measurement abnormal, external memory abnormal, and battery voltage abnormal (battery-powered meter only), etc.	
	Sub display section	Instantaneous flow rate display: 5 digits; Temperature display: 3 digits; Pressure display: 5 digits	

Model		UX25s	UX32
Output	Analog	(Power-driven meter only) 4 to 20 mADC (Load resistance 400 Ω or smaller) Select from Instantaneous flow rate, Temperature, and Pressure. Standard: Instantaneous flow rate	
	Pulse	Nch open drain output (Max. load 24 VDC, 50 mA) Output 1 (accumulated pulse): Standard: 1000L/P (Select from 1, 10, 100, 1000, and 10000L/P.) Duty 20 to 80% Output 2 (alarm): (Power-driven) Select upper and lower limit alarm or upper limit alarm of accumulated flow volume. (Battery-driven) Select battery voltage decrease alarm or upper and lower limit alarm.	
	Communication ^{*2)}	(Power-driven only) Complies with RS485 Modbus/RTU. (4800 bps/9600 bps)	
Fluid temperature		-10 to +60°C	
Operating environment temperature/humidity		-10 to +60°C, 90%RH *No condensation.	
Protection structure ^{*3)}		Outdoor IP64 (JIS C 0920)	
Mass		Approx. 2.7kg	
Others		Battery type, 24VDC type : CE marking, UKCA marking, RoHS Directive compliant 100VAC type : RoHS Directive compliant	

*1) See Table 2 and Table 3 (page 32) for the conversion flow-rate range.

*2) For detailed specifications, download them from our web site.

*3) If the flow meter is exposed to direct sunlight, providing a sunshade or using the optional cover is recommended.

*4) The output interval is updated at intervals of measurement every 10 seconds for Built-in battery Model (Type B) and every 0.5 second for External power supply Model (Type D,R).

*5) In case a distance from an elbow of minimum 10D in the upstream side and 5D in the downstream side of the meter can be secured: $\pm 2.0\%RD$

7-2. Glossary of terms used in specifications

- Actual flow rate
Cubic volume of the fluid which flows per unit of time. The actual flow rate changes depending on the temperature and pressure of fluid. The unit of fluid is m³/h.
- Normal conversion flow-rate
The volumetric flow rate obtained by converting the temperature and pressure with which the actual flow rate is measured into 0°C and 1 atmosphere (1 atm). The unit of fluid is m³/h (Normal).
- Standard conversion flow rate
The volumetric flow rate obtained by converting the temperature and pressure with which the actual flow rate is measured into the conversion standard temperature and conversion standard pressure. The unit of fluid is m³/h (Standard).
The conversion standard temperature (-10 to 60°C) and conversion standard pressure (0.00 to 10.00 kPa) can be changed by buttons and communication (external power supply (24 VDC, 100 VAC) only).

Table 2 Normal conversion flow-rate values [m³/h (Normal)][Conversion example]

Pressure (kPa)		0 (atmospheric pressure)		2		10		100		500		
Temperature (°C)		0	30	0	30	0	30	0	30	0	30	
Actual flow rate (m ³ /h)	25A	1.6	0.70	0.63	0.71	0.64	0.77	0.69	1.39	1.25	0.70	0.63
	32A	80	35.00	31.54	35.69	32.16	38.45	34.65	69.54	62.66	35.00	31.54

Conversion standard temperature = 0°C, Conversion standard pressure = 0 kPa (gauge pressure)

Table 3 Standard conversion flow rate value [m³/h (Standard)] [Conversion example]

Pressure (kPa)		0 (atmospheric pressure)		2		10		100		500		
Temperature (°C)		0	30	0	30	0	30	0	30	0	30	
Actual flow rate (m ³ /h)	25A	1.6	0.74	0.66	0.75	0.68	0.81	0.73	1.46	1.32	0.74	0.66
	32A	80	36.84	33.19	37.56	33.85	40.47	36.47	73.19	65.95	36.84	33.19

Conversion standard temperature = 20°C, Conversion standard pressure = 2 kPa (gauge pressure)

- Pressure loss

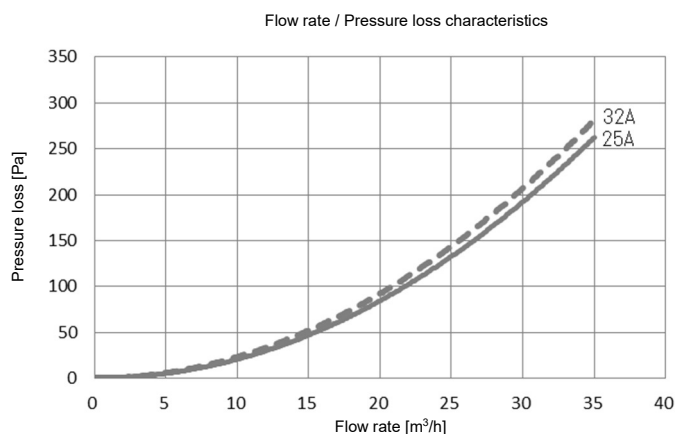

The pressure loss in the air is as shown in the figure on the left.

To calculate the pressure loss of each gas type, multiply the specific gravity shown below.

- City gas (13A) : 0.64
- Butane : 1.55
- Propane : 2.0
- Nitrogen : 0.97
- Argon : 1.38

8. Setting of parameters

It is recommended to perform the settings of the flow meter prior to installation.

On this product, setting of the items shown in Table 4 can be made by button operation and RS485 communication.

At the time of factory shipment, the standard factory delivery settings in Table 4 are set, and the user can use the flow meter as it is. Change the settings according to the usage, if needed.

For operation and setting of buttons, see 4.3 Setting of parameters in 4. Operation Procedure.

For setting by RS485 communication, see communication specifications "TS-UX-003-TG."

You can download the communication specifications from our web site.

Table 4 Setting items and settings in Settings mode

Panel Display	Corresponding setting item	Scope of setting contents	Upon factory shipment Setting contents
F01	Flow-rate conversion selection	OFF/ON	Type without pressure sensor: OFF Type with pressure sensor: ON
F02	Conversion standard temperature	-10 to 60°C	0 °C
F03	Conversion standard pressure	000.0 to 10.00 kPa	0.00 kPa
F04	Output pulse constant	1, 10, 100, 1000, 10000 L/P	1000 L/P
F05	Operating gas pressure setting value	[UX] 0.00 to 100.00 kPa	10 kPa
F06	Alarm output selection	[BT] Battery voltage decrease alarm output Flow rate upper and lower limit alarm output [DC, AC] Accumulated value upper limit alarm output Flow rate upper and lower limit alarm output	Flow rate upper and lower limit alarm output
F07	State of alarm output contact	N.O (Normally open) N.C (Normally closed)	N.O (Normally open)
F08	Alarm output lower limit	0.0 to +9999.9 m ³ /h	0.0 m ³ /h
F09	Alarm output upper limit	0.0 to +9999.9 m ³ /h	9999.9 m ³ /h
F10	Alarm output Hysteresis width	0.0 to +9999.9 m ³ /h	0.0 m ³ /h
F11	Analog output Full scale flow-rate	0.0 to +9999.9 m ³ /h	*See "F11" in 8-1. Details of setting items.
F12	Switchover of analog output	Instantaneous flow-rate, temperature, pressure	Instantaneous Flow-rate
F13	Communication bit rate	4800 bps, 9600 bps	9600 bps
F14	RTU address	001 to 247	001
F15	Instantaneous flow-rate moving average number of times	1 to 16 times	4 times

Panel Display	Corresponding setting item	Scope of setting contents	Upon factory shipment Setting contents
F16	Test mode time selection	3 min., 60 min., Unlimited	3 min.
F17	Gas type selection	13A, propane, butane, nitrogen, argon	*The gas type specified by the customer upon order is set.
F18	Low flow cutoff value	*See "F18" in 8-1. Details of setting items.	25sA: 0.14 m ³ /h 32A: 0.14m ³ /h
F19	Atmospheric pressure of the working environment	0.0 to 200.0 kPa	101.3 kPa
F20	Selection of with or without pressure value moving averaging	No (1 time), Yes (10 times)	Yes (10 times)
F21	With or without pressure zero-cut	"With zero-cut (ON) , Without zero-cut (OFF)	Type with pressure sensor: With zero-cut (ON)

The setting items can be divided mainly into 3 categories.

- 1) Items related to fluid
- 2) Items related to measurement and display
- 3) Items related to output

1) Setting of items related to fluid

[1] Setting related to gas type [F17]

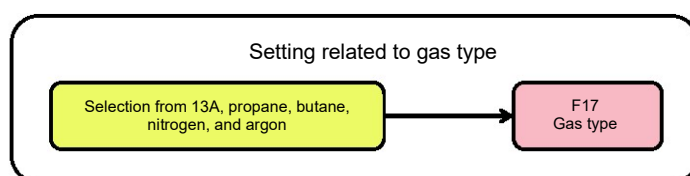

Set the gas type to be used. Since the gas type specified upon order is set at the time of factory shipment, there is no need to change this setting.

“Air” displayed in the selection window is designed for maintenance, and therefore you cannot select it for normal use.

[2] Setting related to pressure [F5] (Available only for type without pressure sensor)

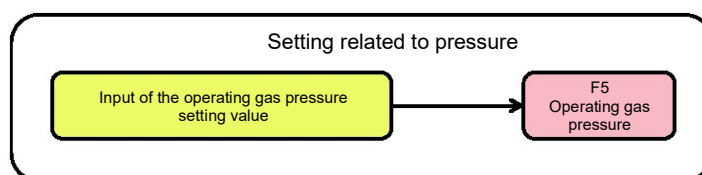

Set the pressure value of the environment in gauge pressure.

Example) When the pressure value of the environment is 2.00 kPa in gauge pressure: Setting value in [F5] “2.00”

2) Setting of items related to measurement and display

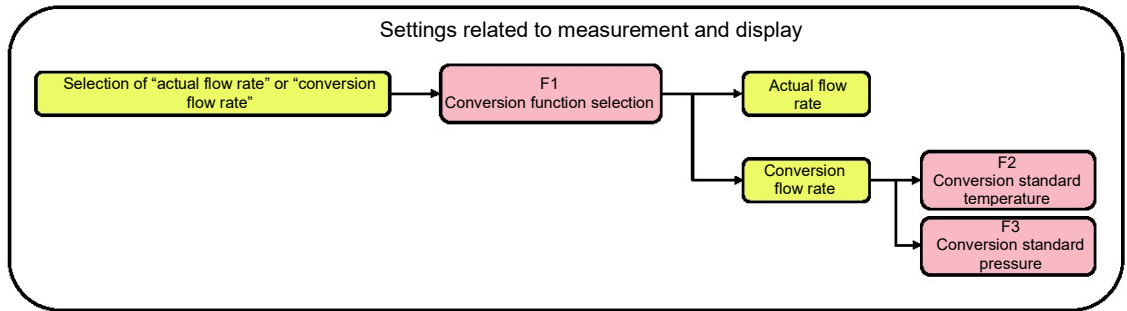

- [1] Setting of conversion function selection [F1] (Available only for type with pressure sensor)
- Set "Actual flow-rate" or "Conversion flow-rate". When "Conversion flow rate" is selected, the accumulation display, instantaneous display, and output signal correspond to the converted flow volume based on the settings of [F2] and [F3]. When the setting of [F1] Flow-rate conversion selection is changed, the setting value of [F4] Output pulse constant is automatically changed to 1000 [L/P]. After setting [F1], set [F4] again according to need.
- [2] Setting of conversion standard temperature [F2] and setting of conversion standard pressure [F3]
- When you select "Conversion flow rate" in [F1], set the standard temperature and pressure to be used for conversion. When 0°C is set to the conversion standard temperature, and 0.0 kPa is set to the conversion standard pressure, the conversion flow-rate becomes normal conversion flow-rate. When any value other than 0°C is set to the conversion standard temperature, and any value other than 0.0 kPa is set to the conversion standard pressure, the conversion flow-rate becomes standard conversion flow-rate.
- When you select "Actual flow rate" in [F1], the settings of the standard temperature and pressure to be used for conversion become invalid.

3) Setting of items related to output

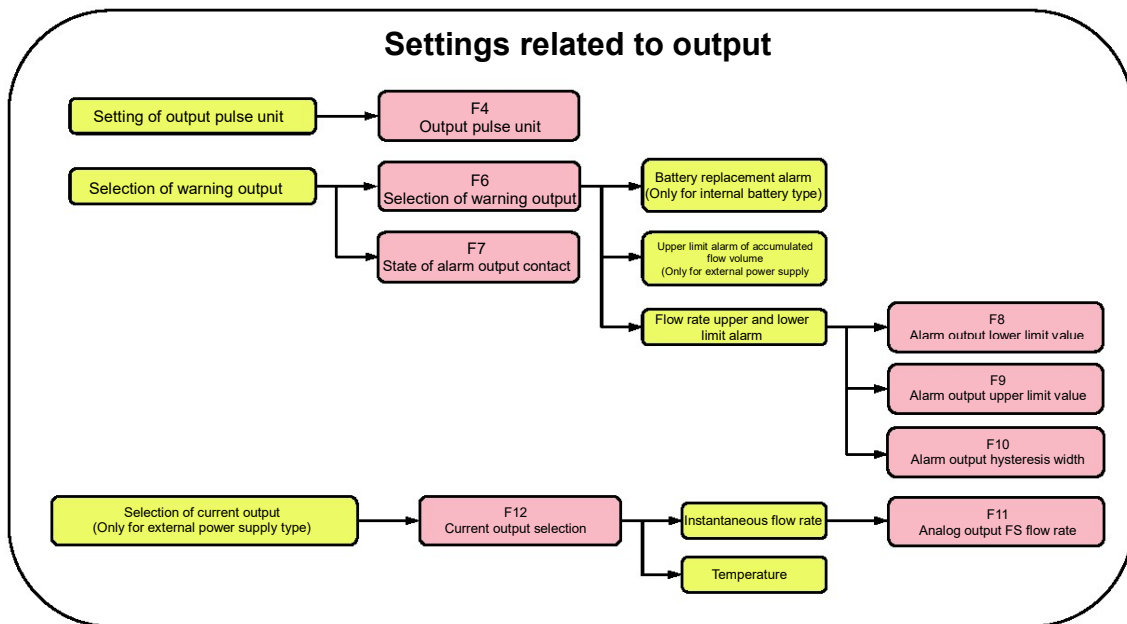

[3] Setting of output pulse constant [F4]

When you use pulse output, set the output pulse constant according to the usage in advance.

[4] Setting of alarm output selection [F6]

The selectable alarm output items vary according to the power supply type as shown below:

Internal battery type

: Flow rate upper/lower limit alarm
or battery replacement alarm

External power supply type (24 VDC, 100 VAC): Flow rate upper/lower limit
alarm or upper limit alarm of
accumulated flow volume

Flow rate upper/lower limit alarm can be output and stopped at any flow-rate
value. When you select this function, set the alarm output lower limit value [F8],
alarm output upper limit value [F9], and alarm output hysteresis width [F10].

[5] Analog output selection [F12]

As the analog output type, you can select instantaneous flow-rate, temperature, or pressure according to the usage.

When you select instantaneous flow-rate, current based on the maximum flow-rate value setting of analog output is output.

When you select temperature, 4 mA is output at -10°C, and 20 mA is output at +60°C.

You can select pressure only for the type with pressure sensor. The currents shown below are output according to the model.

[UX]: 4 mA at 0 kPa, 20 mA at 100 kPa

Setting of maximum flow-rate value of analog output (Analog output FS flow-rate) [F11]

When you use analog output for instantaneous flow-rate, it is recommended to set the full scale flow-rate (FS flow-rate) of analog output based on the maximum flow-rate. It is recommended to set a numeric value with margin as the setting value of the FS flow-rate.

For reference, a conversion example is shown in Table 2 and Table 3 (page 32).

8-1.Details of setting items

The items with *1 to *3 are displayed only for the corresponding models shown below and not displayed for other models.

- *1 Type with pressure sensor only
- *2 Type without pressure sensor only
- *3 DC type and AC type only
- [F1] About flow-rate conversion selection
As the flow-rate conversion, you can select the actual flow-rate, normal conversion flow-rate, or standard conversion flow-rate.
You can select the actual flow-rate, normal conversion flow-rate, or standard conversion flow-rate using the settings of [F1] Flow-rate conversion selection, [F2] Conversion standard temperature, and [F3] Conversion standard pressure. (See Table 5.)

Table 5 Display/output values based on [F1] to [F3] settings

[F1] Flow-rate conversion selection	[F2] Conversion standard temperature, [F3] Conversion standard pressure	Flow rate
No	-	Actual flow rate
Yes	0°C and 0.00 kPa	Normal conversion flow-rate
	Other than "0°C and 0.00 kPa"	Standard conversion flow rate

If you select "Yes" for conversion, the "Normal" or "Standard" lamp above the partition line will flash, and the accumulated flow volume display, instantaneous flow-rate display, and output signal will all correspond to the converted flow volume. If you select "No" for conversion, the "Normal" or "Standard" lamp above the partition line will be turned OFF, and the accumulated flow volume display, instantaneous flow-rate display, and output signal will all correspond to the actual flow-rate.

When flow-rate conversion selection is set (and even if the setting is not changed), the output pulse constant is automatically changed to 1000 [L/P], which is set at the time of factory setting.

Example: When "No" is changed to "Yes"

Output pulse constant 10 L/P, No conversion

↓ "Yes" is selected.

Output pulse constant 1000 L/P, Normal flow-rate or Standard flow-rate

Conversion is internally calculated as shown below.

$$Q_n = (T + t_0) / (T + t_1) \times (P + p_1) / (P + p_0) \times Q_r$$

Q_r : Actual flow-rate [m³/h]

Q_n : Conversion flow-rate [Normal (Standard)•m³/h]

T : 273.15 [K] (Absolute temperature of 0°C)

t_1 : measured temperature [°C]

t_0 : Conversion standard temperature [°C] (Set in Settings mode [F2])

P : 101.33 [kPa abs] (Absolute pressure of 1 atm)

p_0 : Conversion standard pressure (Set in Settings mode [F3])

p_1 : measured pressure value (gauge pressure) [kPa]

When you use both the external output function and conversion flow-rate, it is recommended to set the output constant in reference to the conversion example Table 2 and Table 3 (page 32).

- [F2] Conversion standard temperature
When you select “Conversion flow rate” in [F1] Conversion function selection, set the temperature to be used as the standard for conversion.
The value can be set within the range of -10°C to 60°C in 1°C steps.
When you select “Actual flow rate”, the setting of the conversion standard temperature becomes invalid.
- [F3] Conversion standard pressure
When you select “Conversion flow rate” in [F1] Conversion function selection, set the pressure to be used as the standard for conversion.
When you select “Actual flow rate”, the setting of the conversion standard pressure becomes invalid.
- [F4] About output pulse constant
Select the output pulse constant from “10000”, “1000”, “100”, and “10”.
(Unit is [L/P].)
This setting may not be available depending on the combination of the model and flow-rate conversion selection.
An option indicating that the item cannot be selected is not displayed. (See Table 6.)

Table 6 Output pulse constant

Model	Nominal diameter	Pressure sensor	Conversion	Output pulse constant [L/P]				
				1	10	100	1000	10000
UX	25s 32	0	OFF	○	○	○	○	○
			ON	■	○	○	○	○
		100	OFF	○	○	○	○	○
			ON	■	○	○	○	○

○ Selectable

■ Not selectable

When the setting of [F1] Conversion function selection is changed, the setting value of [F4] Output pulse constant is automatically changed to 1000 [L/P]. After setting [F1], set [F4] again according to need.

- [F5] About operating gas pressure setting value (*2)
Set the pressure value of the environment in gauge pressure.
Set the value in the range of 0 to 100.00 [kPa] in increments of 0.01 [kPa].
- [F6] About alarm output selection
The selectable alarm output items vary according to the power supply type as shown below:
Internal battery type : Flow rate upper/lower limit alarm or battery replacement alarm
External power supply type (24 VDC, 100 VAC) : Flow rate upper/lower limit alarm or upper limit alarm of accumulated flow volume

<Flow rate upper and lower limit alarm output>

In alarm output, an alarm signal is output when the instantaneous flow-rate exceeds the alarm output upper limit value or it becomes lower than the alarm output lower limit value. An alarm signal is stopped when the instantaneous flow-rate exceeds the (alarm output lower limit value + alarm output hysteresis width) or it becomes lower than the (alarm output upper limit value - alarm output hysteresis width) while an alarm is output.

Make the setting in a way that the (alarm output upper limit value) > (alarm output lower limit value + alarm output hysteresis width).

<Battery replacement alarm>

When 5 years pass after the battery connector is connected (the power is turned on), an alarm signal is output as the time to replace the battery.

<Upper limit alarm of accumulated flow volume>

When the accumulated flow volume for 1 hour after the power is turned on becomes higher than the specified accumulated flow volume, an alarm signal is output, and that state is kept for 1 hour.

When a message to reset the accumulated value upper limit alarm is received through communication, the alarm output is stopped, but observation of the accumulated value per hour continues.

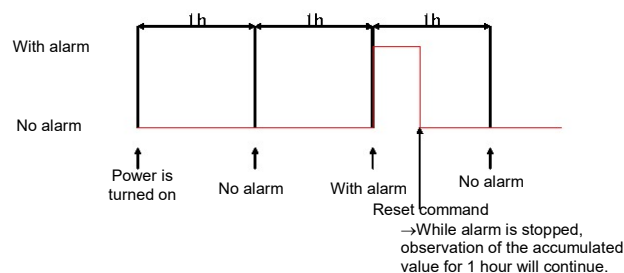

The upper value of the accumulated flow volume is set via communication.

*For detailed communication specifications, download them from our web site.

- [F7] About state of alarm output contact
As the state of the alarm output contact, select either "Normally open (n. OP)" or "Normally closed (n. CL)."
Set this to "Normally open" in case of using a battery-powered signal receiving device.
- [F8] About alarm output lower limit
Set the flow-rate value at the lower limit side of the upper/lower limit flow-rate alarm output. When it is used by "conversion flow-rate", set the conversion value.
- [F9] About alarm output upper limit
Set the flow-rate value at the upper limit side of the upper/lower limit flow-rate alarm output. When it is used by "conversion flow-rate", set the conversion value.
- [F10] About hysteresis width for alarm output
With regard to the flow-rate value defined for the upper and lower limits of the upper/lower limit flow-rate alarm output, set the flow-rate range to stop the alarm output. When it is used by "conversion flow-rate", set the conversion value.
For instance, when the upper limit of the flow-rate is set to 7.00 [m³/h], the lower limit of the flow-rate is set to 2.00 [m³/h], and alarm output hysteresis width is set to 1.00 [m³/h], an alarm is output when the flow rate exceeds 7.00 [m³/h], and the alarm stops when the flow rate becomes lower than 6.00 [m³/h] at the upper limit side. Likewise, at the lower limit side, an alarm is output when the flow rate becomes lower than 2.00 [m³/h], and the alarm stops when the flow rate becomes larger than 3.00 [m³/h].
- [F11] About full scale flow-rate for analog output (*3)
Set the full scale flow-rate value when the instantaneous flow-rate is set for analog output. When you use analog output for the conversion flow rate, set the converted full scale flow-rate.

The flow rate values shown below are set at the time of factory shipment.

	[Nominal diameter]	[Pressure]	Full scale flow-rate value [m ³ /h]
UX	25s	0	35
	32	100	100

- [F12] About analog output selection (*3)
Select the output signal of analog output from "Instantaneous flow-rate (FLo)", "Temperature (tEP)", and "Pressure (PrS)".
Note that "Pressure" can be selected only for the type with pressure sensor. ("Pressure" is not displayed for the type without pressure sensor.)
- [F13] About communication bit rate (*3)
Select either 4800 bps (4800)" or "9600 bps (9600)" for your communication bit rate.
- [F14] About RTU address (*3)
Select a value between 001 to 247 for the RTU address.
- [F15] About moving average number of times
Select the moving average number of times for display and output of the instantaneous flow-rate. The moving average number of times is set to 4 times upon factory shipment, and the immediate 4 measurement values are adopted.
While there is no need to change the moving average number of times under normal usage, you can select 1 to 16 times. When you select 1 time, "no moving average" is set.
- [F16] About test mode time selection
You can select the test mode time. At the time of factory shipment, "3 min. (3)" is set. You can select "60 min. (60)" and "Unlimited (--)" in addition to 3 min.
- [F17] Gas type selection
Select the gas type to be measured from "13 A (13A)" "Propane (Pro)", "Butane (but)", "Nitrogen (n2)", and "Argon (Ar)".
"Air" displayed in the selection window is designed for maintenance, and therefore you cannot select it for normal use.
Since the gas type specified upon order is set at the time of factory shipment, there is no need to change this setting under normal use.
- [F18] Low flow cutoff value
Set the low flow cutoff value where the instantaneous flow-rate is 0 m³/h.
The settable range is defined as $0 \leq \text{Low flow cutoff value} < Q$ (See Table 7).
When you use this value for the conversion flow-rate, set the conversion value.

Table 7 Upper limit of low flow cutoff value

Model	Flow-rate Q [m ³ /h]
UX25s	0.14
UX32	0.14

- [F19] Atmospheric pressure of the working environment
Set the atmospheric pressure of the working environment in absolute pressure [kPa].
At the time of factory shipment, 101.3 [kPa] is set.
There is no need to change this setting under normal use. However, if the setting value at the time of factory shipment is used at a high altitude place, error in accuracy occurs when calculating the conversion flow-rate.
The relationship between the altitude, atmospheric pressure, and maximum error in accuracy is shown in Table 8. (Reference value)

Table 8 Atmospheric pressure of the working environment

Altitude (m)	Atmospheric pressure (absolute pressure) (kPa)	Max. error in accuracy (%) (Atmospheric pressure of the working environment: 101.3 kPa Measured pressure value: 0 kPa (gauge pressure))
0	101.3	±0.0
200	98.95	+2.4
400	96.61	+4.9
1000	89.87	+12.7

- [F20] Selection of with or without pressure value moving averaging (*1)
Select either "With averaging (10)" or "No averaging (1)" for pressure values.
If "With averaging" is selected, the moving average value of the 10 most recently measured pressures is used for display and output.
- [F21] With or without pressure zero-cut (*1)
Select "With zero-cut (on)" or "Without zero-cut (oFF)" for zero-cut of pressure value.
If "With zero-cut (on)" is selected, in the case that the measured pressure value is 5[kPa] or less, the pressure value is indicated and outputted as 0[kPa]. In the case the setting of "pressure value averaging" is "With averaging", zero-cut judgment is to be done based on the pressure value of moving average after such averaging.

A diagram showing the display changeover in each setting mode is given below.

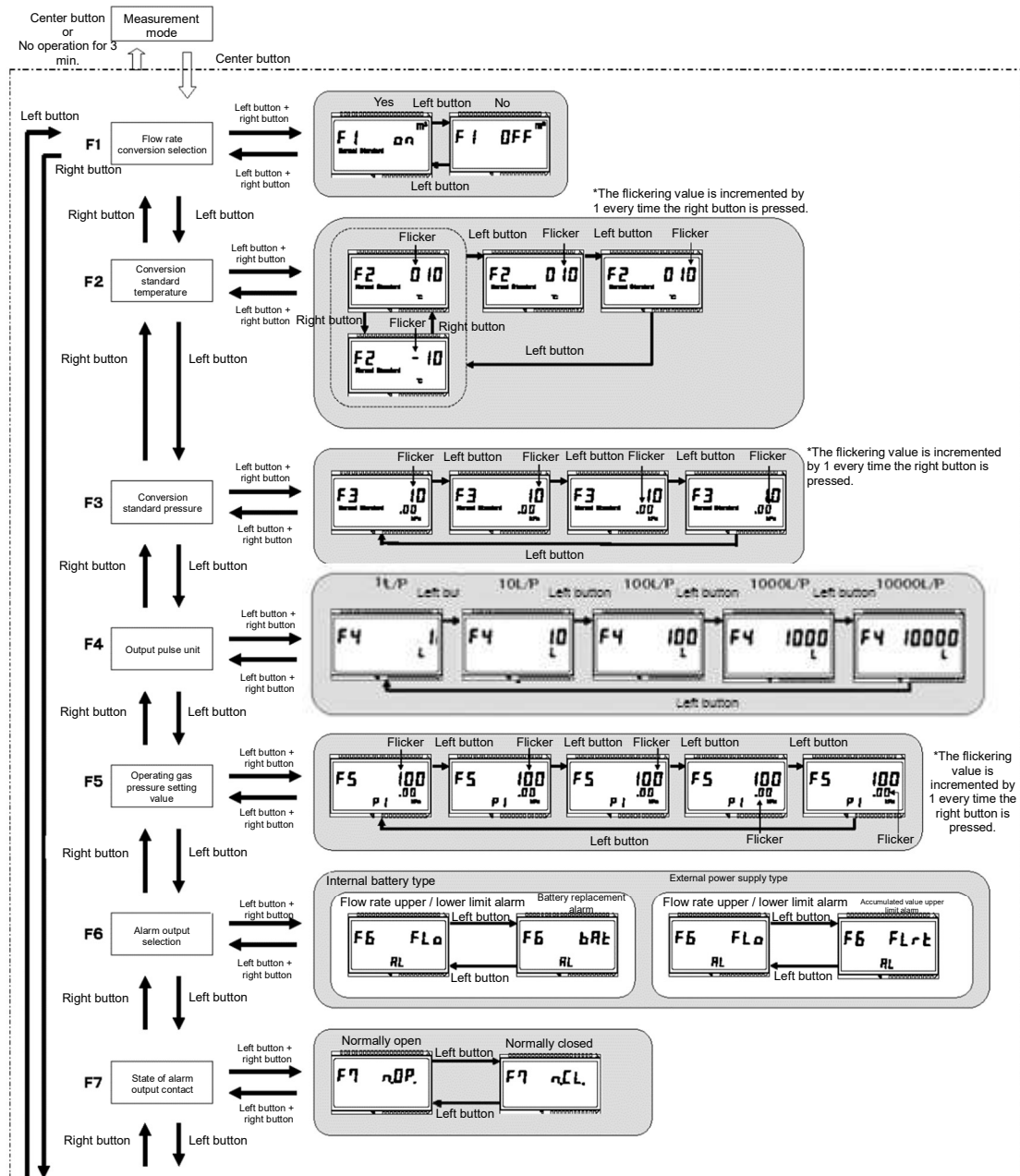

Fig. 7 Display changeover in each setting mode

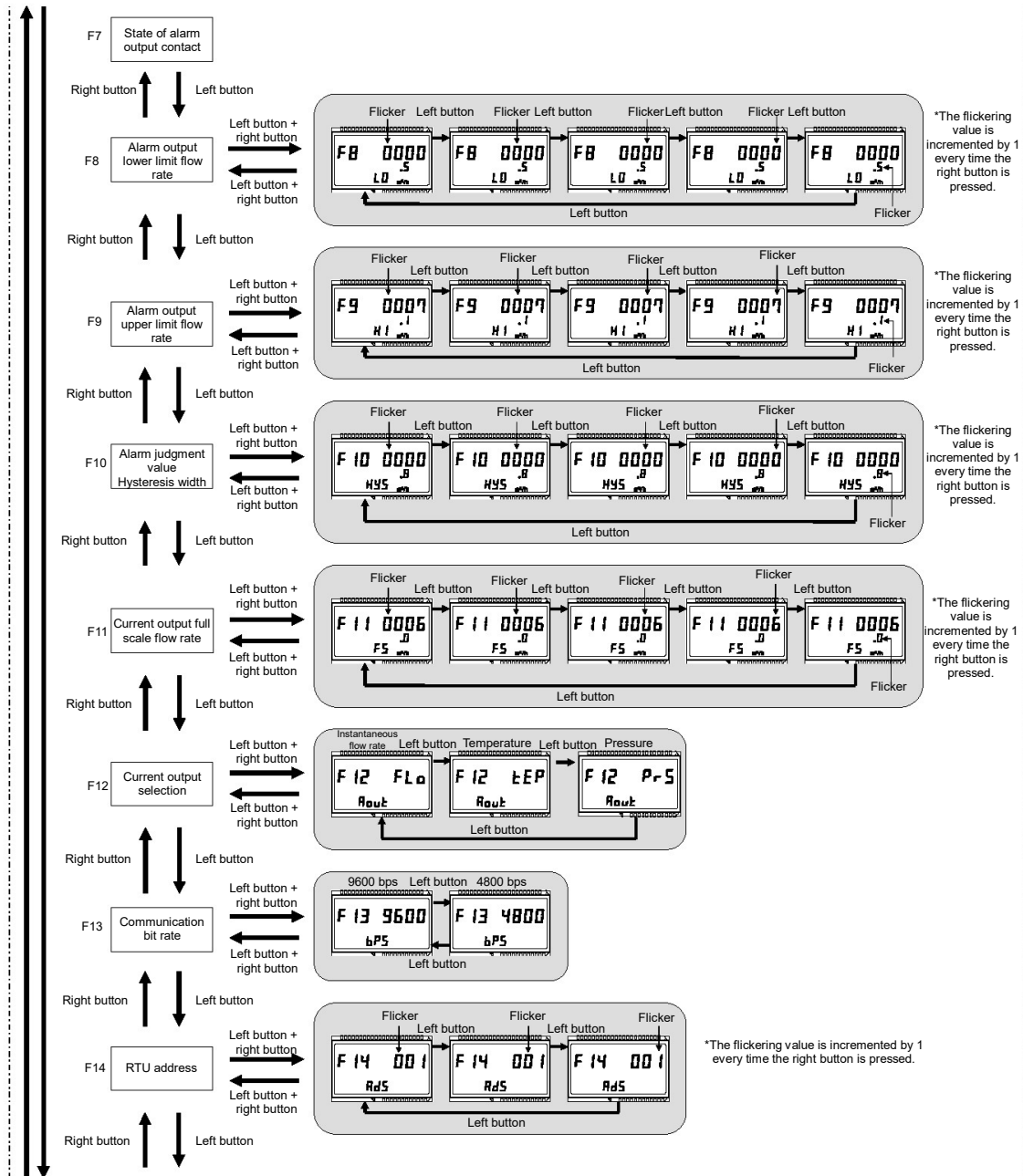

Fig. 8 Display changeover in each setting mode

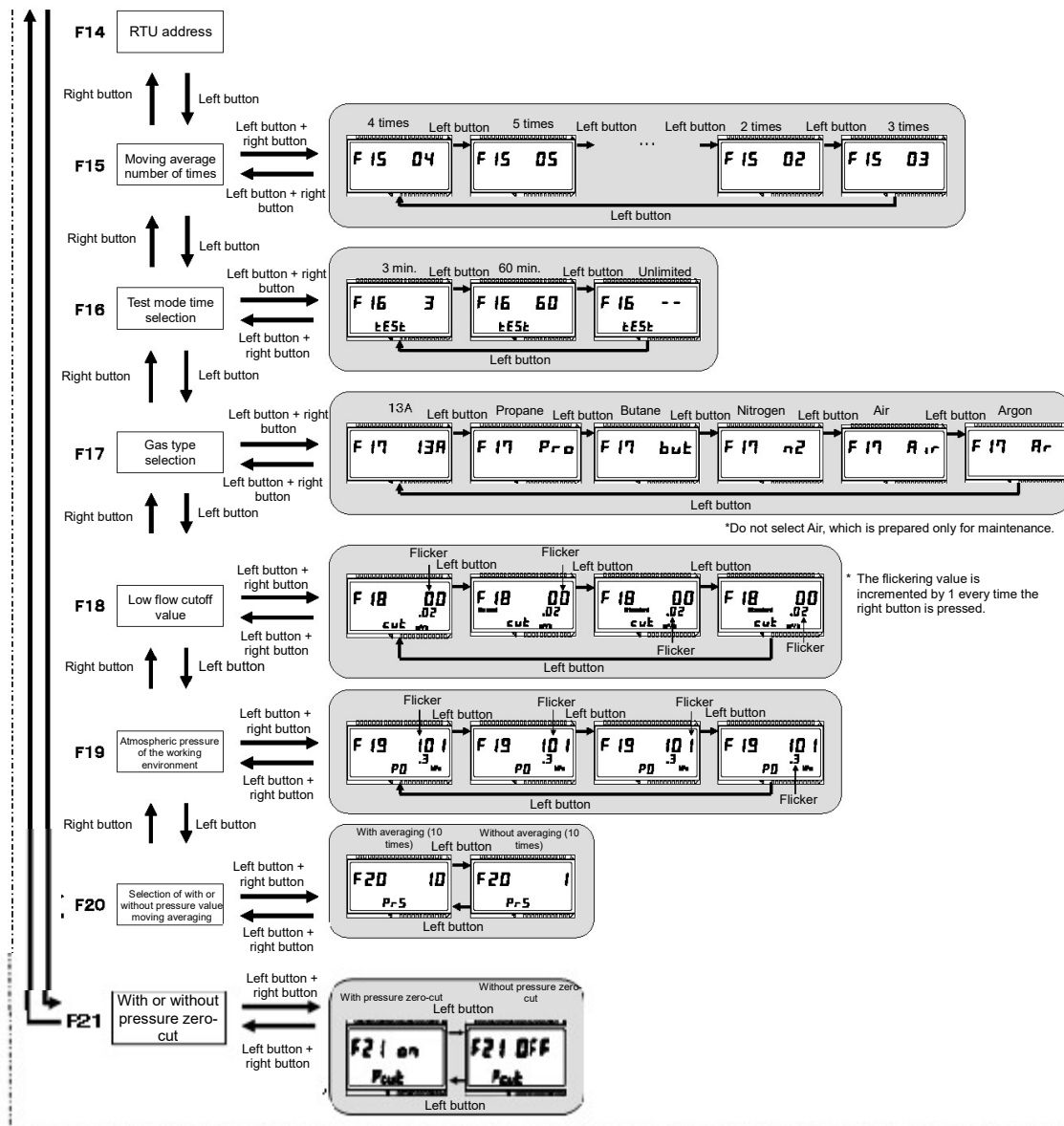

Fig. 9 Display changeover in each setting mode

Warranty and after-sale service

1) Warranty period

For the period of one year after purchase, in case of a failure that is explicitly attributable to our manufacturing process, we will exchange the product for free.

2) Scope of warranty

The followings are not included in the scope of warranty.

Failure caused by force majeure, such as natural disaster, etc.

Disassembly or alteration of the product.

Failure caused by mishandling.

Failure caused by use in excess of the scope of the specifications (environment, etc.)

Other cases determined to be not attributable to our responsibility

Warranty specified here applies to our product itself, and any damage (loss and/or damage of any products other than our product, lost earning, and lost opportunity, etc.) incurred by the customer due to a failure of our product is excluded from the scope of warranty.

3) Requesting for service

Regardless of whether or not your warranty has expired, please contact the company you purchased the product from or our branch or sales office branch or sales office with the product name, model, construction work number, serial number, and a detailed description of the failure.

4) Points to note for long-term use



Warning

[Designed standard operating period] 10 years

The designed standard operating period refers to the standard period in which the product can be used after installation without safety problems against time-related degradation under the standard conditions (environment temperature 20°C, environment humidity 65%RH).

If you use the product longer than the designed standard operating period, safety problems of the product itself may occur such as deterioration of water-proof/dust-proof performance, smoke, fire, and electrical shock, etc.

If the designed standard operating period has passed, please use the product as checking if there is any failure in the product and consider replacing it with a new one.

The designed standard operating period is different from the warranty period. It does not guarantee that a general failure will not occur.

Memo

Ver. 3
2023.07